

# EMBEDDED SYSTEM DESIGN

## UNIT 1

### INTRODUCTION TO EMBEDDED SYSTEM

#### **Embedded systems overview**

An embedded system is nearly any computing system other than a desktop computer. An embedded system is a dedicated system which performs the desired function upon power up, repeatedly.

Embedded systems are found in a variety of common electronic devices such as consumer electronics ex. Cell phones, pagers, digital cameras, VCD players, portable Video games, calculators, etc.,

Embedded systems are found in a variety of common electronic devices, such as:

(a) consumer electronics -- cell phones, pagers, digital cameras, camcorders, videocassette recorders, portable video games, calculators, and personal digital assistants; (b) home appliances -- microwave ovens, answering machines, thermostat, home security, washing machines, and lighting systems; (c) office automation -- fax machines, copiers, printers, and scanners; (d) business equipment -- cash registers, curbside check-in, alarm systems, card readers, product scanners, and automated teller machines; (e) automobiles -- transmission control, cruise control, fuel injection, anti-lock brakes, and active suspension

#### Classifications of Embedded systems

1. **Small Scale Embedded Systems:** These systems are designed with a single 8- or 16-bit microcontroller; they have little hardware and software complexities and involve board-level design. They may even be battery operated. When developing embedded software for these, an editor, assembler and cross assembler, specific to the microcontroller or processor used, are the main programming tools. Usually, `_C` is used for developing these systems. `_C` program compilation is done into the assembly, and executable codes are then appropriately located in the system memory. The software has to fit within the memory available and keep in view the need to limit power dissipation when system is

running continuously.

2. **Medium Scale Embedded Systems:** These systems are usually designed with a single or few 16- or 32-bit microcontrollers or DSPs or Reduced Instruction Set Computers (RISCs). These have both hardware and software complexities. For complex software design, there are the following programming tools: RTOS, Source code engineering tool, Simulator, Debugger and Integrated Development Environment (IDE). Software tools also provide the solutions to the hardware complexities. An assembler is of little use as a programming tool. These systems may also employ the readily available ASSPs and IPs (explained later) for the various functions—for example, for the bus interfacing, encrypting, deciphering, discrete cosine transformation and inverse transformation, TCP/IP protocol stacking and network connecting functions.
3. **Sophisticated Embedded Systems:** Sophisticated embedded systems have enormous hardware and software complexities and may need scalable processors or configurable processors and programmable logic arrays. They are used for cutting edge applications that need hardware and software co-design and integration in the final system; however, they are constrained by the processing speeds available in their hardware units. Certain software functions such as encryption and deciphering algorithms, discrete cosine transformation and inverse transformation algorithms, TCP/IP protocol stacking and network driver functions are implemented in the hardware to obtain additional speeds by saving time. Some of the functions of the hardware resources in the system are also implemented by the software. Development tools for these systems may not be readily available at a reasonable cost or may not be available at all. In some cases, a compiler or retargetable compiler might have to be developed for these.

#### The processing units of the embedded system

1. **Processor in an Embedded System** A processor is an important unit in the embedded system hardware. A microcontroller is an integrated chip that has the processor, memory and several other hardware units in it; these form the microcomputer part of the embedded system. An embedded processor is a processor with special features that allow it to be embedded into a system. A digital signal processor (DSP) is a processor meant for applications that process digital signals.

2. Commonly used microprocessors, microcontrollers and DSPs in the small-, medium-and large scale embedded systems
3. A recently introduced technology that additionally incorporates the application-specific system processors (ASSPs) in the embedded systems.
4. Multiple processors in a system.

Embedded systems are a combination of hardware and software as well as other components that we bring together into products such as cell phones, music player, a network router, or an aircraft guidance system. They are a system within another system as we see in Figure 1.1

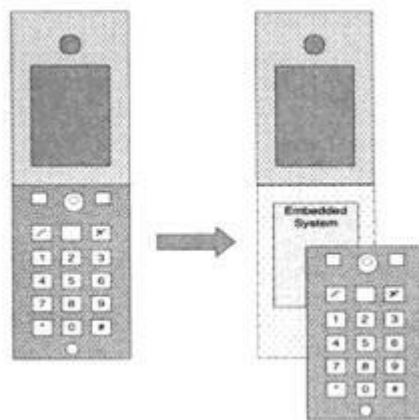

Figure 1.1: A simple embedded system

## **Building an embedded system**

We embed 3 basic kinds of computing engines into our systems: microprocessor, microcomputer and microcontrollers. The microcomputer and other hardware are connected via a system bus. A system bus is a single computer bus that connects the major components of a computer system. The technique was developed to reduce costs and improve modularity. It combines the functions of a data bus to carry information, an address bus to determine where it should be sent, and a control bus to determine its operation.

The system bus is further classified into address, data and control bus. The microprocessor controls the whole system by executing a set of instructions called firmware that is stored in ROM.

An instruction set, or instruction set architecture (ISA), is the part of the computer architecture related to programming, including the native data types, instructions, registers, addressing modes, memory architecture, interrupt and exception handling, and external I/O. An ISA includes a specification of the set of opcodes (machine language), and the native commands implemented by a particular processor. To run the application, when power is first turned ON, the microprocessor addresses a predefined location and fetches, decodes, and executes the instruction one after the other. The implementation of a microprocessor based embedded system combines the individual pieces into an integrated whole as shown in Figure 1.2, which represents the architecture for a typical embedded system and identifies the minimal set of necessary components.

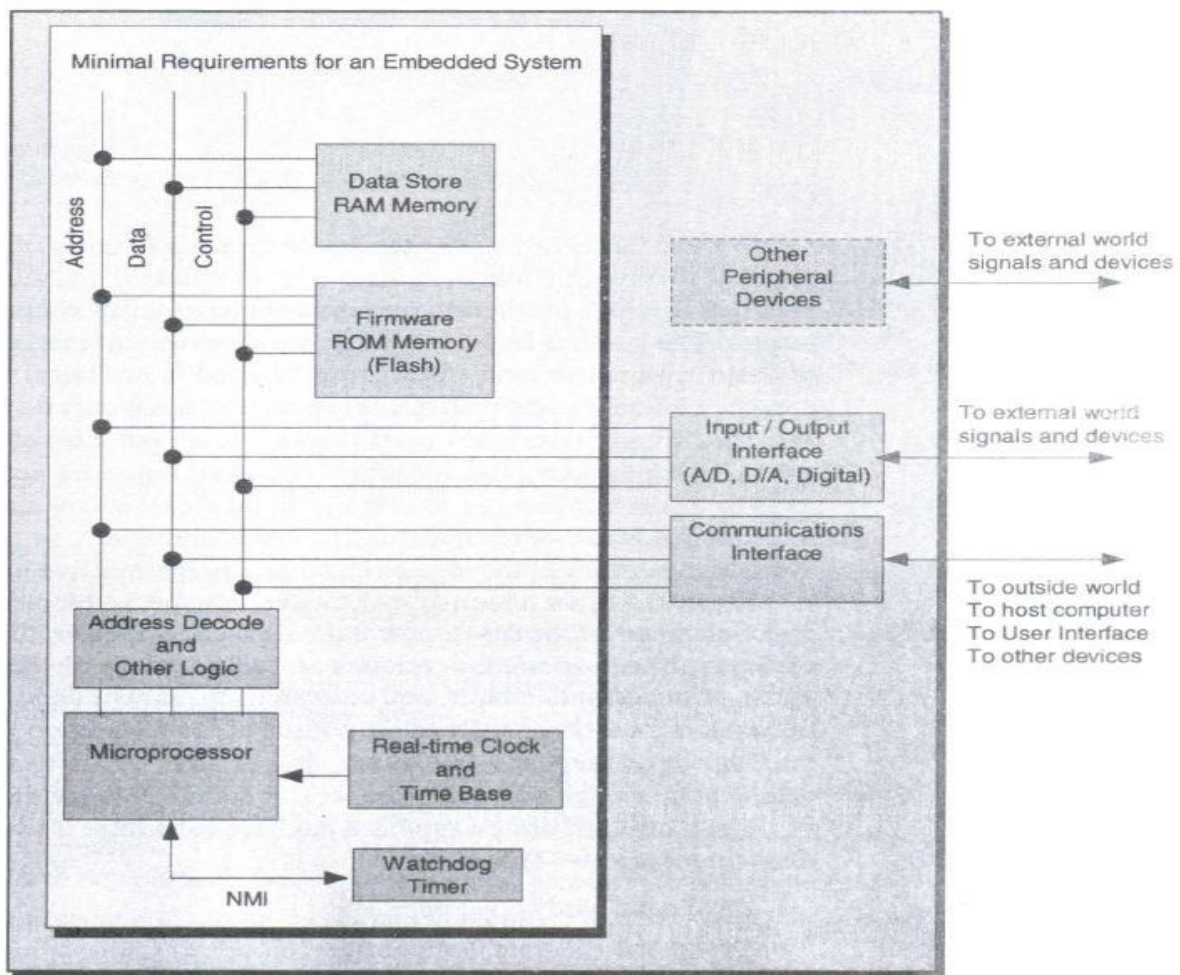

Figure 1.2 :A Microprocessor based Embedded system

## Embedded design and development process

Figure 1.3 shows a high level flow through the development process and identifies the major elements of the development life cycle.

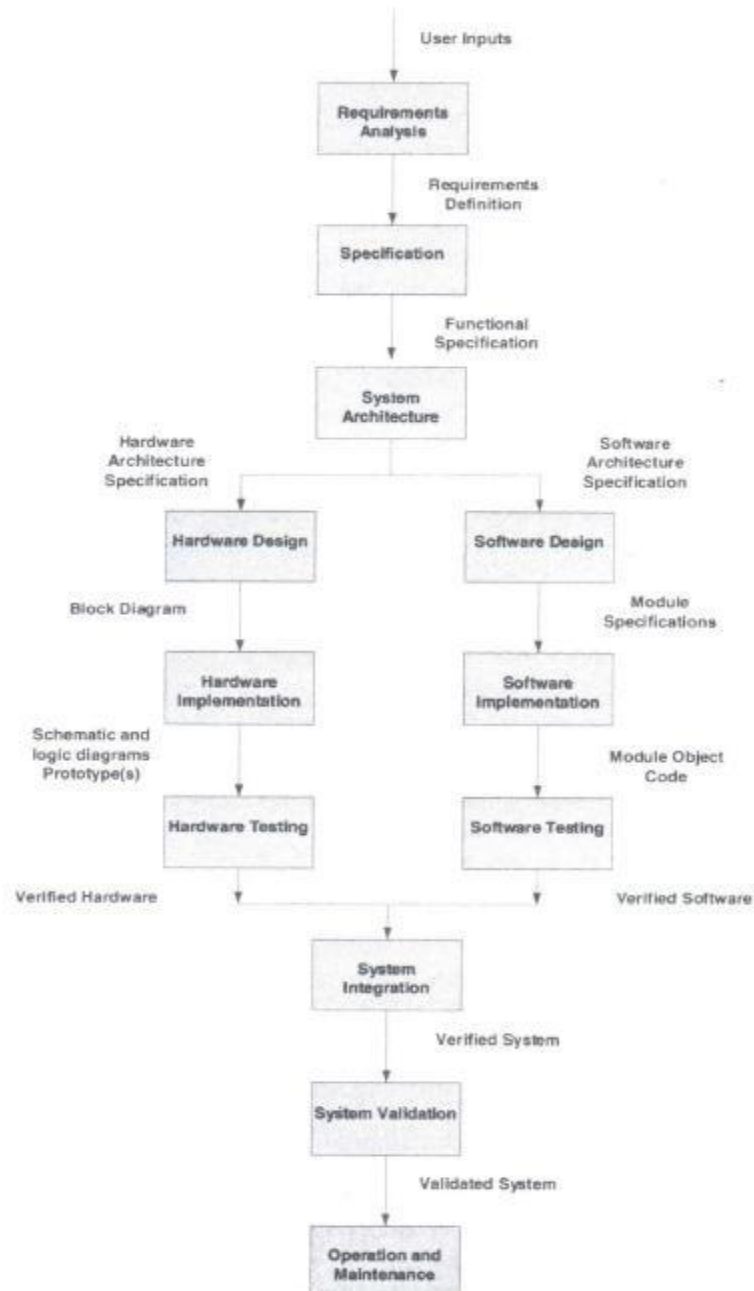

Figure 1.3 Embedded system life cycle

The traditional design approach has been traverse the two sides of the accompanying diagram separately, that is,

- Design the hardware components
- Design the software components.
- Bring the two together.
- Spend time testing and debugging the system.

The major areas of the design process are

- Ensuring a sound software and hardware specification.
- Formulating the architecture for the system to be designed.
- Partitioning the h/w and s/w.
- Providing an iterative approach to the design of h/w and s/w.

The important steps in developing an embedded system are

- Requirement definition.
- System specification.
- Functional design
- Architectural design
- Prototyping.

The major aspects in the development of embedded applications are

- Digital hardware and software architecture
- Formal design , development, and optimization process.
- Safety and reliability.
- Digital hardware and software/firmware design.
- The interface to physical world analog and digital signals.
- Debug, troubleshooting and test of our design.

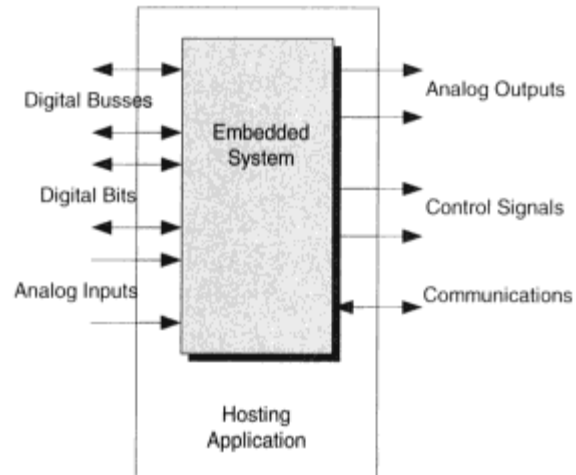

Figure 1.4: Interfacing to the outside world

Embedded applications are intended to work with the physical world, sensing various analog and digital signals while controlling, manipulating or responding to others. The study of the interface to the external world extends the I/O portion of the von-Neumann machine as shown in figure 1.4 with a study of buses, their constituents and their timing considerations.

### **Exemplary applications of each type of embedded system**

Embedded systems have very diversified applications. A few select application areas of embedded systems are Telecom, Smart Cards, Missiles and Satellites, Computer Networking, Digital Consumer Electronics, and Automotive. Figure 1.9 shows the applications of embedded systems in these areas.

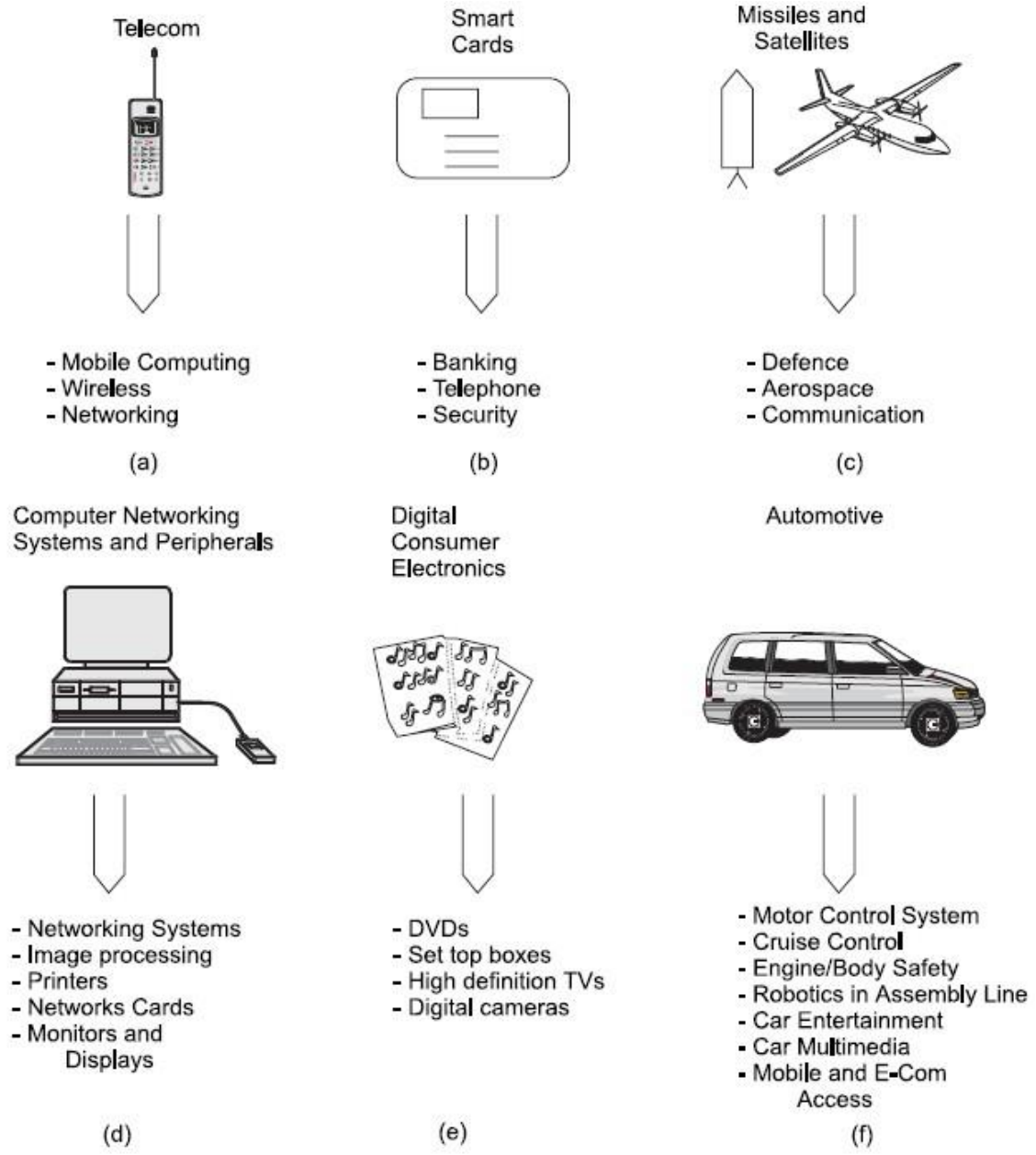

Figure 1.9 Applications of embedded systems



## UNIT 2

### THE HARDWARE SIDE

In today's hi-tech and changing world, we can put together a working hierarchy of hardware components. At the top, we find VLSI circuits comprising of significant pieces of functionality: microprocessor, microcontrollers, FPGA's, CPLD, and ASIC.

Our study of hardware side of embedded systems begins with a high level view of the computing core of the system. we will expand and refine that view of hardware both inside and outside of the core. Figure 2.1 illustrates the sequence.

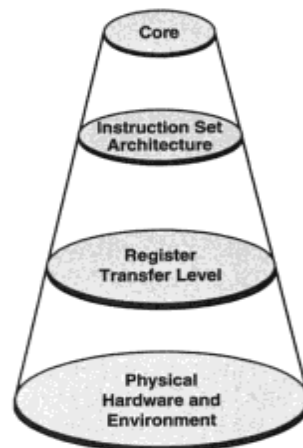

Figure 2.1 Exploring embedded systems

#### The core level

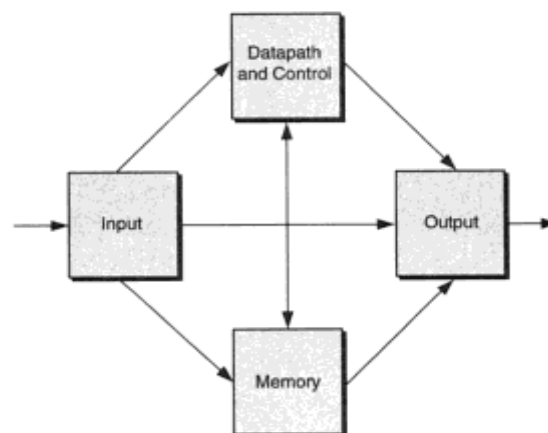

Figure 2.2 Four major blocks of an embedded hardware core

At the top, we begin with a model comprising four major functional blocks i.e., input, output, memory and data path and control depicting the embedded hardware core and high level signal flow as illustrated in figure 2.2.

The source of the transfer is the array of eight bit values; the destination is perhaps a display. in figure 2.3, we refine the high level functional diagram to illustrate a typical bus configuration comprising the address, data and control lines.

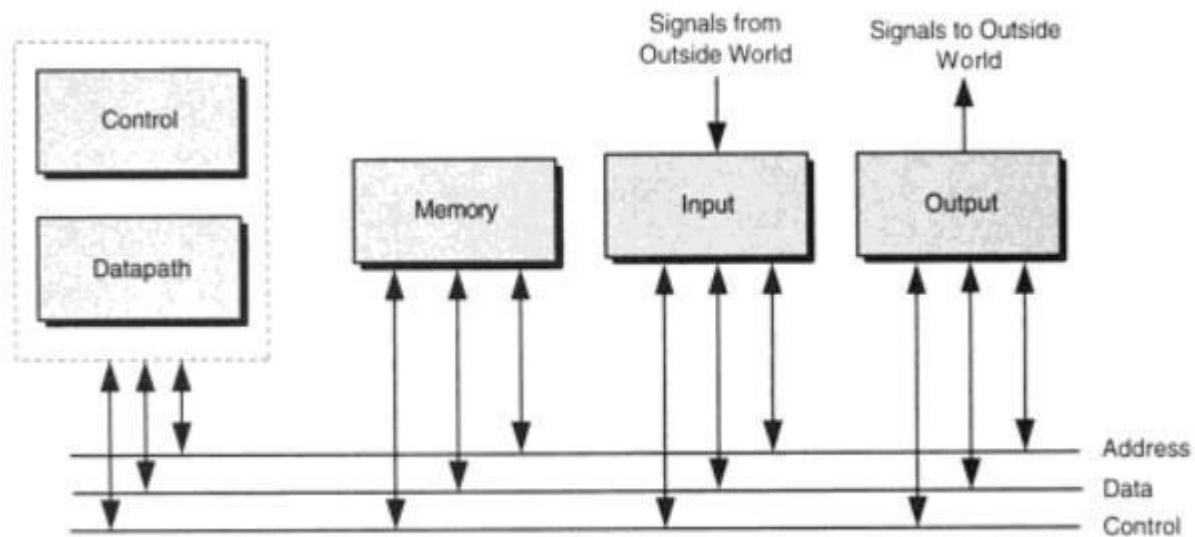

Figure 2.3 A typical Bus structure comprising address, data and control signals.

## The Microprocessor

A microprocessor (sometimes abbreviated  $\mu\text{P}$ ) is a programmable digital electronic component that incorporates the functions of a central processing unit (CPU) on a single semiconducting integrated circuit (IC). It is a multipurpose, programmable device that accepts digital data as input, processes it according to instructions stored in its memory, and provides results as output. It is an example of sequential digital logic, as it has internal memory. Microprocessors operate on numbers and symbols represented in the binary numeral system.

A microprocessor control program can be easily tailored to different needs of a product line, allowing upgrades in performance with minimal redesign of the product. Different features

can be implemented in different models of a product line at negligible production cost. Figure 2.4 shows a block diagram for a microprocessor based system.

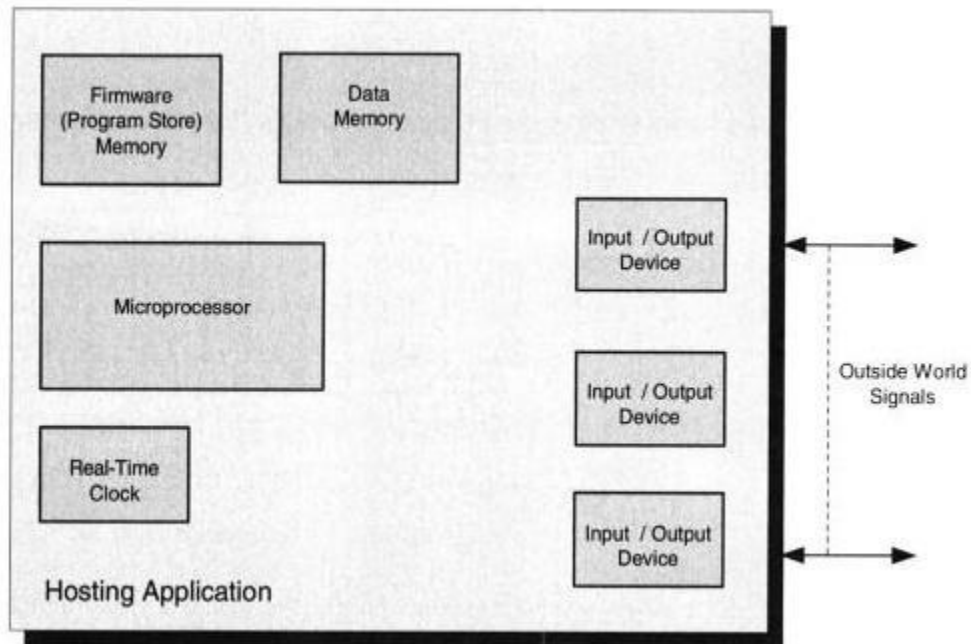

Figure 2.4 : A block diagram for a microprocessor based system

## The microcomputer

The microcomputer is a complete computer system that uses a microprocessor as its computational core. Typically, a microcomputer will also utilize numerous other large scale integrated circuits to provide necessary peripheral functionality. The complexity of microcomputers varies from simple units that are implemented on a single chip along with a small amount of on chip memory and elementary I/O system to the complex that will augment the microprocessor with a wide array of powerful peripheral support circuitry.

## The microcontroller

A microcontroller (sometimes abbreviated  $\mu\text{C}$ ,  $\text{uC}$  or  $\text{MCU}$ ) is a small computer on a single integrated circuit containing a processor core, memory, and programmable input/output peripherals. Program memory in the form of NOR flash or OTP

ROM is also often included on chip, as well as a typically small amount of RAM. Microcontrollers are designed for embedded applications, in contrast to the microprocessors used in personal computers or other general purpose applications.

Figure 2.5 shows together the microprocessor core and a rich collection of peripherals and I/O capability into a single integrated circuit.

Microcontrollers are used in automatically controlled products and devices, such as automobile engine control systems, implantable medical devices, remote controls, office machines, appliances, power tools, toys and other embedded systems. By reducing the size and cost compared to a design that uses a separate microprocessor, memory, and input/output devices, microcontrollers make it economical to digitally control even more devices and processes. Mixed [signal](#) microcontrollers are common, integrating analog components needed to control non-digital electronic systems.

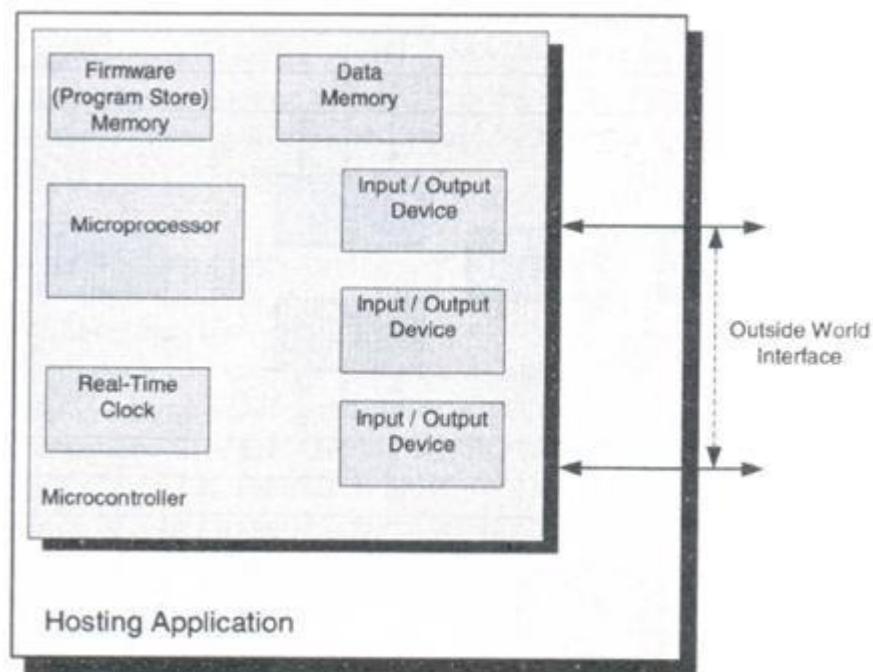

Figure 2.5 :A block diagram for a microcontroller based system

## The digital signal processor

A digital signal processor (DSP) is a specialized microprocessor with an architecture optimized for the operational needs of digital signal processing. A DSP provides fast, discrete-

time, signal-processing instructions. It has Very Large Instruction Word (VLIW) processing capabilities; it processes Single Instruction Multiple Data (SIMD) instructions fast; it processes Discrete Cosine Transformations (DCT) and inverse DCT (IDCT) functions fast. The latter are a must for fast execution of the algorithms for signal analyzing, coding, filtering, noise cancellation, echo-elimination, compressing and decompressing, etc. Figure 2.6 shows the block diagram for a digital signal processor

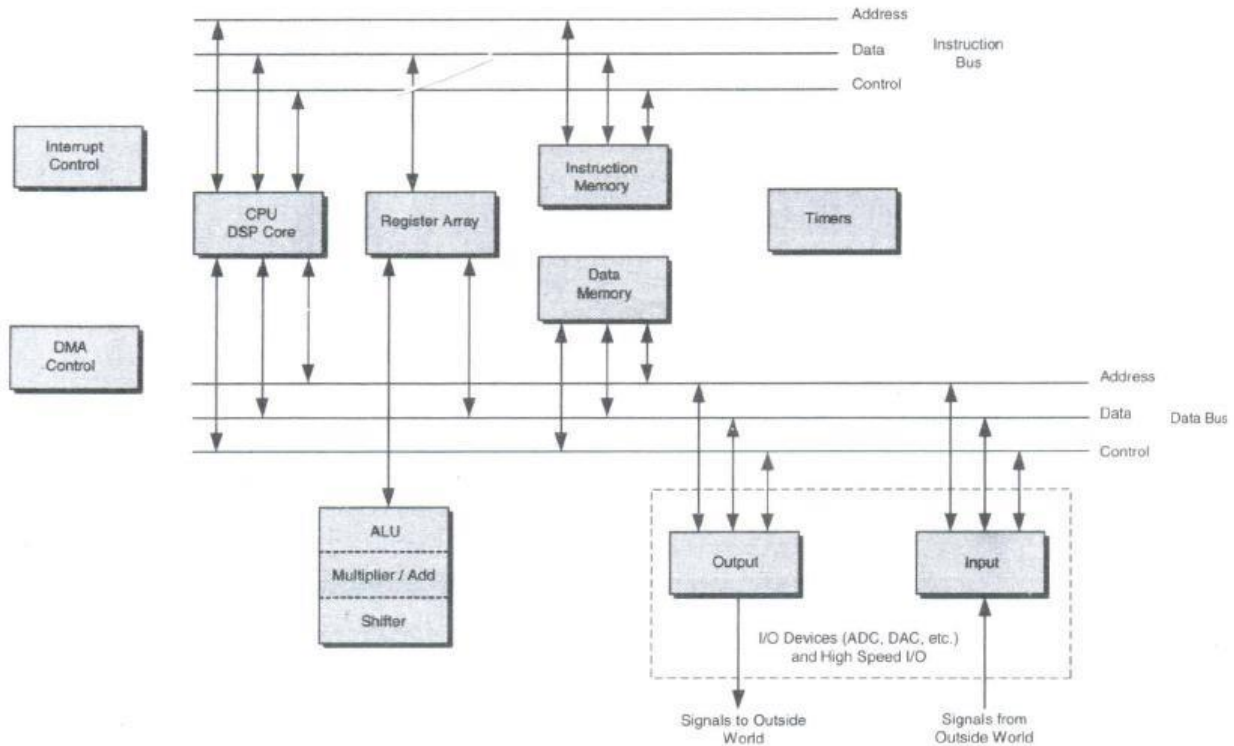

Figure 2.6 A block diagram for a digital signal processor

By the standards of general-purpose processors, DSP instruction sets are often highly irregular. One implication for software architecture is that hand-optimized [assembly-code](#) routines are commonly packaged into libraries for re-use, instead of relying on advanced compiler technologies to handle essential algorithms.

Hardware features visible through DSP instruction sets commonly include:

- Hardware modulo addressing, allowing circular buffers to be implemented without having to constantly test for wrapping.

- Memory architecture designed for streaming data, using DMA extensively and expecting code to be written to know about cache hierarchies and the associated delays.
- Driving multiple arithmetic units may require memory architectures to support several accesses per instruction cycle
- Separate program and data memories (Harvard architecture), and sometimes concurrent access on multiple data busses
- Special SIMD (single instruction, multiple data) operations
- Some processors use VLIW techniques so each instruction drives multiple arithmetic units in parallel
- Special arithmetic operations, such as fast multiply–accumulates (MACs). Many fundamental DSP algorithms, such as FIR filters or the Fast Fourier transform (FFT) depend heavily on multiply–accumulate performance.
- Bit-reversed addressing, a special addressing mode useful for calculating FFTs
- Special loop controls, such as architectural support for executing a few instruction words in a very tight loop without overhead for instruction fetches or exit testing
- Deliberate exclusion of a **memory management unit**. DSPs frequently use multi-tasking operating systems, but have no support for **virtual memory** or memory protection. Operating systems that use **virtual memory** require more time for **context switching** among **processes**, which increases latency.

## Representing Information

$$\text{Int } i = 450 = 2^8 + 2^7 + 2^6 + 2 = \text{x000001C2}$$

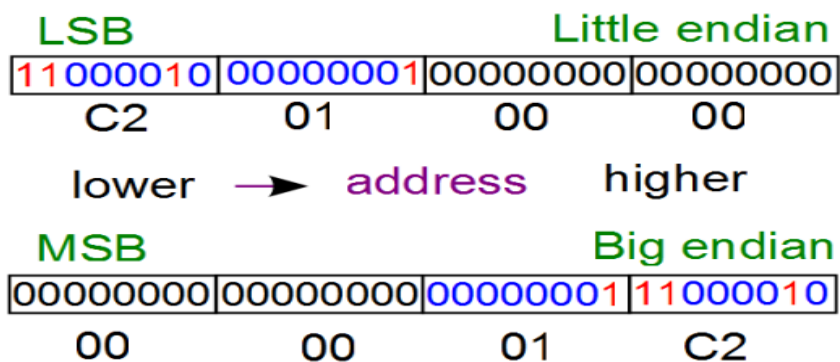



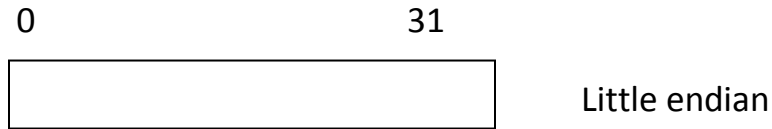

Figure Expressing Addresses

## Instructions

An **instruction set**, or **instruction set architecture (ISA)**, is the part of the computer architecture related to programming, including the native data types, instructions, registers, addressing modes, memory architecture, interrupt and exception handling, and external I/O. An ISA includes a specification of the set of opcodes (machine language), and the native commands implemented by a particular processor.

The entities that instructions operate on are denoted Operand. The number of operands that an instruction operates on at any time is called the arity of the operation.

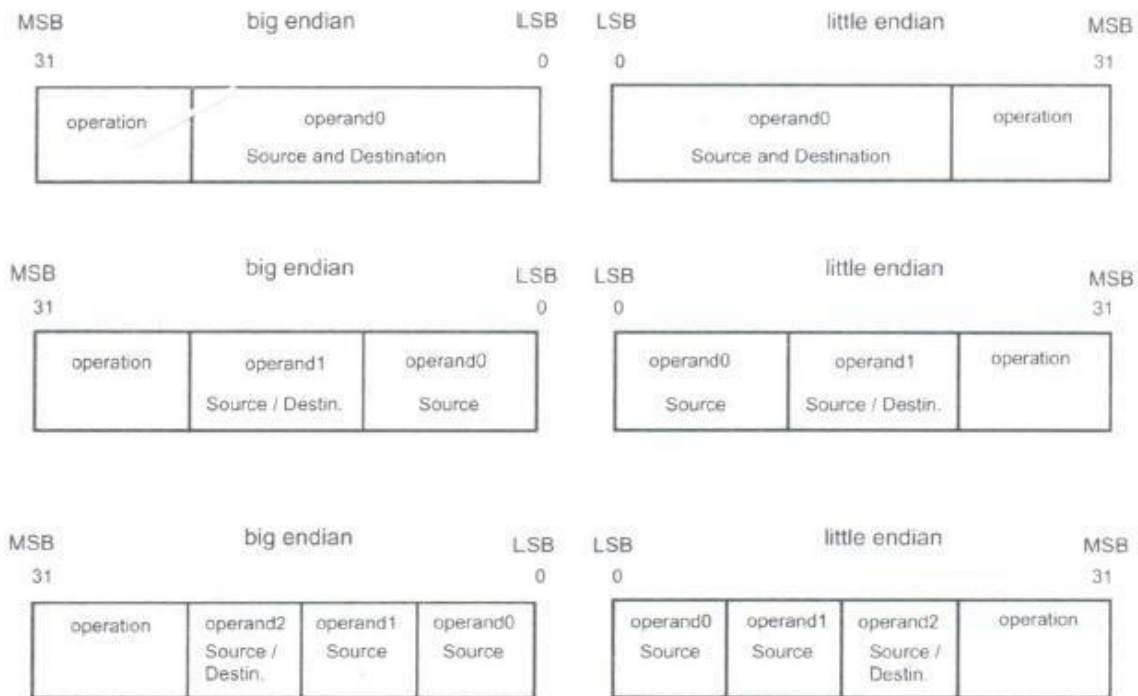

Figure 2.7 Expressing Instructions



In figure 2.7 ,we see that within the 32 bit word, the bit are aggregated into groups or fields. Some of the fields are interpreted as the operation to be performed, and others are seen as the operands involved in the operation.

## **Embedded systems-An instruction set view**

A microprocessor instruction set specifies the basic operations supported by the machine. From the earlier functional model, we see that the objectives of such operations are to transfer or store data, to operate on data, and to make decisions based on the data values or outcome of the operations, corresponding to such operations, we can classify instructions into the following groups

- Data transfer
- Flow control
- Arithmetic and logic

## **Data transfer Instructions**

Data transfer instructions are responsible for moving data around inside the processor as well as for bringing data in from the outside world or sending data out. The source and destination can be any of the following:

- A register
- Memory
- An input or output

As shown in figure

## **Addressing modes**

There are five addressing modes in 8085.

1.Direct Addressing Mode

1. Register Addressing Mode

2. Register Indirect Addressing Mode

3. Immediate Addressing Mode

4. Implicit Addressing Mode

### **Direct Addressing Mode**

In this mode, the address of the operand is given in the instruction itself.

- LDA is the operation.
- 2500 H is the address of source.
- Accumulator is the destination.

1. Immediate addressing mode:

In this mode, 8 or 16 bit data can be specified as part of the instruction.

OP Code	Immediate Operand
---------	-------------------

Example 1 : MOV CL, 03 H

Moves the 8 bit data 03 H into CL

Example 2 : MOV DX, 0525 H

Moves the 16 bit data 0525 H into DX

In the above two examples, the source operand is in immediate mode and the destination operand is in register mode. A constant such as -VALUE|| can be defined by the assembler EQUATE directive such as VALUE EQU 35H

Example : MOV BH, VALUE

Used to load 35 H into BH

2. Register addressing mode

The operand to be accessed is specified as residing in an internal register of 8086. Example below shows internal registers, any one can be used as a source or destination operand, however only the data registers can be accessed as either a byte or word.

Example 1 : MOV DX (Destination Register) , CX (Source Register)

Which moves 16 bit content of CX into DX.

Example 2 : MOV CL, DL

Moves 8 bit contents of DL into CL

MOV BX, CH is an illegal instruction.

\* The register sizes must be the same.

### 3. Direct addressing mode

The 20 bit physical address of the operand in memory is normally obtained as

PA = DS : EA

But by using a segment override prefix (SOP) in the instruction, any of the four segment registers can be referenced,

$$PA = \left\{ \begin{array}{c} CS \\ DS \\ SS \\ ES \end{array} \right\} : \{ \text{Direct Address} \}$$

The Execution Unit (EU) has direct access to all registers and data for register and immediate operands. However the EU cannot directly access the memory operands. It must use the BIU, in order to access memory operands.

In the direct addressing mode, the 16 bit effective address (EA) is taken directly from the displacement field of the instruction.

Example 1 : MOV CX, START

If the 16 bit value assigned to the offset START by the programmer using an assembler pseudo instruction such as DW is 0040 and [DS] = 3050.

Then BIU generates the 20 bit physical address 30540 H. The content of 30540 is moved to CL  
The content of 30541 is moved to CH

Example 2 : MOV CH, START

If [DS] = 3050 and START = 0040

8 bit content of memory location 30540 is moved to CH.

Example 3 : MOV START, BX

With [DS] = 3050, the value of START is 0040.

Physical address : 30540

1. Register indirect addressing mode :

The EA is specified in either pointer (BX) register or an index (SI or DI) register. The 20 bit physical address is computed using DS and EA.

$$PA = \left\{ \begin{array}{c} CS \\ DS \\ SS \\ ES \end{array} \right\} = \left\{ \begin{array}{c} BX \\ SI \\ DI \end{array} \right\}$$

Example : MOV [DI], BX

If [DS] = 5004, [DI] = 0020, [Bx] = 2456 PA=50060.

The content of BX(2456) is moved to memory locations 50060 H and 50061 H.

2. Based addressing mode:

when memory is accessed PA is computed from BX and DS when the stack is accessed PA is computed from BP and SS.

$$PA = \left\{ \begin{array}{c} CS \\ DS \\ SS \\ ES \end{array} \right\} : \left\{ \begin{array}{c} BX \\ \text{or} \\ BP \end{array} \right\} + \text{displacement}$$

Example : MOV AL, START [BX] or MOV AL, [START + BX]

EA : [START] + [BX]

PA : [DS] + [EA]

The 8 bit content of this memory location is moved to AL.

**Indexed addressing mode:**

$$PA = \left\{ \begin{array}{c} CS \\ DS \\ SS \\ ES \end{array} \right\} : \left\{ \begin{array}{c} SI \\ \text{or} \\ DI \end{array} \right\} + 8 \text{ or } 16\text{bit displacement}$$

Example : MOV BH, START [SI]

PA : [SART] + [SI] + [DS]

The content of this memory is moved into BH

**Based Indexed addressing mode:**

$$PA = \left\{ \begin{array}{c} CS \\ DS \\ SS \\ ES \end{array} \right\} : \left\{ \begin{array}{c} BX \\ or \\ BP \end{array} \right\} + \left\{ \begin{array}{c} SI \\ or \\ DI \end{array} \right\} + 8 \text{ or } 16\text{bit displacement}$$

Example : MOV ALPHA [SI] [BX], CL

If [BX] = 0200, ALPHA – 08, [SI] = 1000 H and [DS] = 3000

Physical address (PA) = 31208

8 bit content of CL is moved to 31208 memory address.

### Execution flow

The execution flow or control flow captures the order of evaluation of each instruction comprising the firmware in an embedded application, we can identify these as

- Sequential
- Branch
- Loop
- Procedure or functional call

Sequential flow-sequential control flow describes the fundamental movement through a program.

Each instruction contained in the program is executed in sequence one after the other.

### Branch-

The control-flow of a language specify the order in which computations are performed

The if-else statement is used to express decisions. Formally the syntax is

if (expression)

statement1

else

statement2

Where the else part is optional. The expression is evaluated; if it is true (that is, if expression has a nonzero value), statement1 is executed. If it is false (expression is zero) and if there is an else part, statement2 is executed instead.

Since a if tests the numeric value of an expression, certain coding shortcuts are possible. The most obvious is writing

```
if (expression)
```

Instead of

```
if (expression != 0)
```

Sometimes this is natural and clear; at other times it can be cryptic

### **Procedure or function call**

The procedure or function invocation is the most complex of the flow of control constructs. CALL operand - when PC is unconditionally saved and replaced by specified operand; the control is transferred to specified memory location.

RET – Previously saved contents of PC are restored, and control is returned to previous context.

### **Arithmetic and logic**

Arithmetic and logic operations are essential elements in affecting what the processor is to do. such operations are executed by any og several hardware components comprising the ALU. Figure 2.8 presents a block diagram for a possible functional ALU architecture.

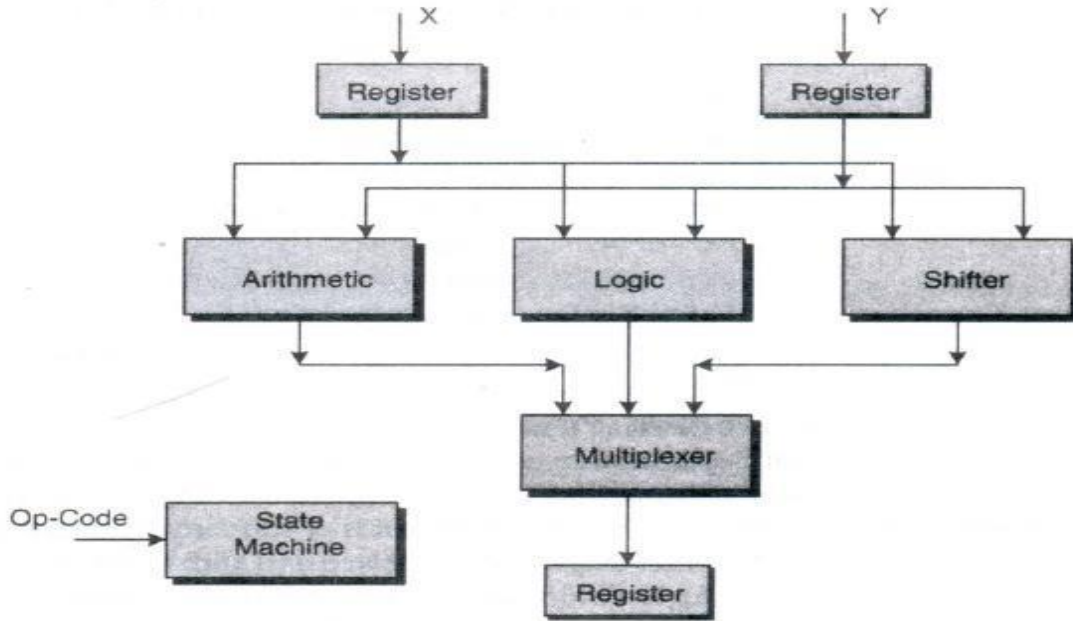

Figure 2.8 A block diagram for a possible functional ALU architecture.

Data is brought into the ALU and held in the local registers. The opcode is decoded, the appropriate operation is performed on the selected operands, and the result is stored in another local register.

### Embedded system-A register view

At the ISA level, the instruction set specifies the basic operations supported by the machine—that is, the external view of the processor from the developer’s perspective. The instruction set expresses the machine’s ability to transfer data, store data, operate on data, and make decision. The core hardware comprises a control unit and a datapath as illustrated in figure 2.9

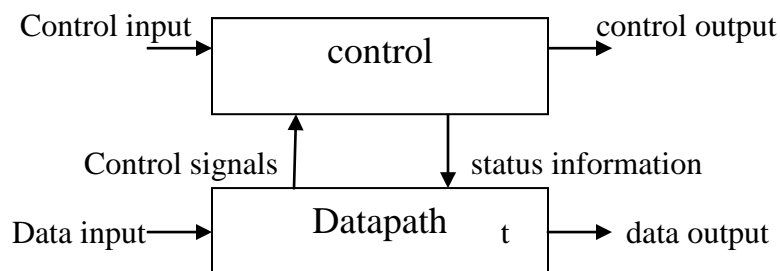

Figure 2.9 A control and datapath block diagram



The data path is a collection of registers and an associated set of micro operations on the data held in the registers. The control unit directs the ordered execution of the micro operations so as to effect the desired transformation of the data. Thus the system's behavior can be expressed by the movement of data among these registers, by operations and transformations performed on the register's contents, and by the management of how such movements and operations take place. The operations on data found at the instruction level are paralleled by a similar, yet more detailed, set of operations at the register level.

## Register view of a Microprocessor

### The datapath

Figure 2.10 expresses the architecture of the datapath and the memory interface for a simple microprocessor at the register transfer level.

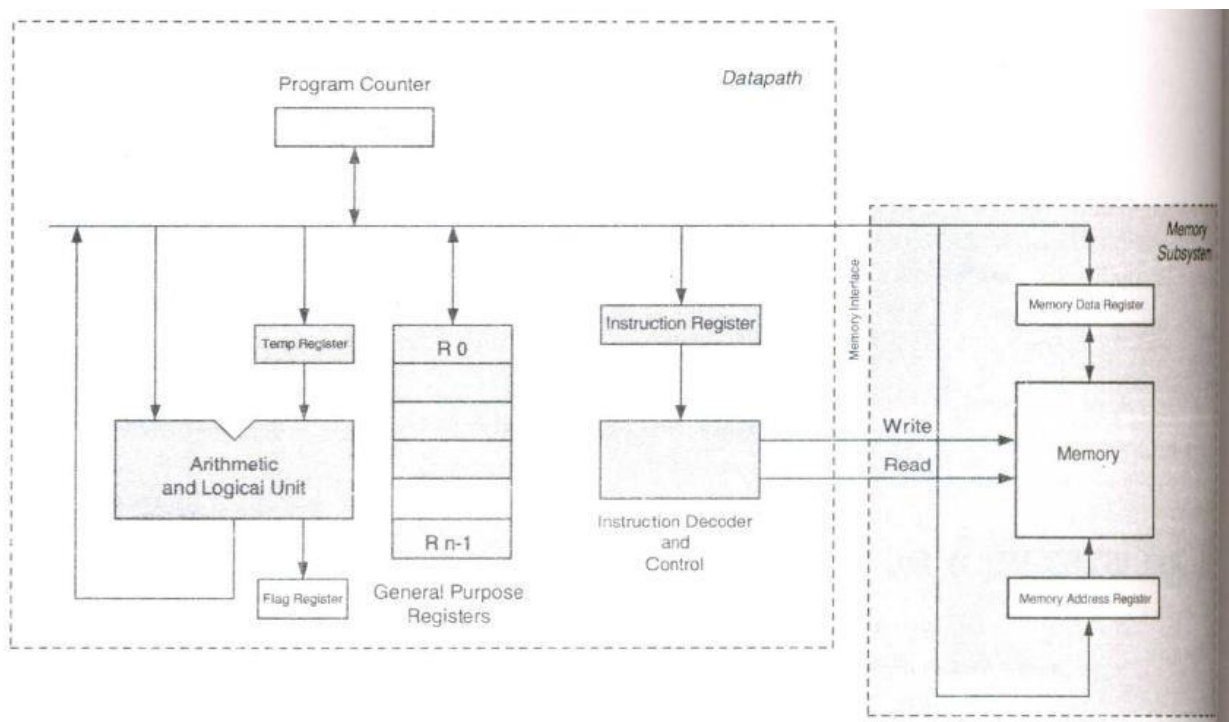

Figure 2.10 Architecture of the datapath and the memory interface

### Processor control

The control of the microprocessor data path comprises four fundamental operations defined as the instruction cycle. The steps are identified in figure 2.11.

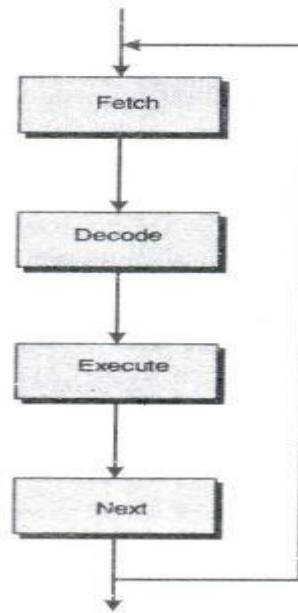

Figure 2.11 The instruction cycle

**Fetch**-The fetch operation retrieves an instruction from memory. That instruction is identified by its address, which is the contents of the PC.

**Decode**-The decode step is performed when the opcode field in the instruction is extracted from the instruction and decoded by the decoder. That information is forwarded to the control logic, which will initiate the execute portion of the instruction cycle.

**Execute**-Based on the value contained in the opcode field, the control logic performs the sequence of steps necessary to execute the instruction.

**Next**-The address of the next instruction to be executed is dependent on the type of instruction to be executed and potentially, on the state of the condition flags as modified by the recently completed instruction.

## **The Hardware side-storage elements and finite state machines**

The logic devices that we have studied so far are combinational. The outputs of such circuitry are a function of inputs only, they are valid as long as the inputs are true. If the input changes, the output changes.

## The concepts of State and Time

**Time** - A combinational logic system has no notion of time or history. The present output does not depend in any way on how the output values are achieved. Neglecting the delays through the system, we find that the output is immediate and a direct function of the current input set. Time is an integral part of the behavior of a system.

**State** -In an analog circuits, we define branch and mesh currents and branch or node voltages. The values these variables assume over time characterize the behavior of that circuit. If we know the values of the specified variables over time, we know the behavior of the circuit. Such variables are called state variables. We define the state of a system at any time as a set of values for such variables; each set of values represents a unique state.

### State changes

In traditional logic, a simple memory device, represented by a single variable, has two states binary 1 and 0. The device will remain in the state until changed. For a set of variables, the state changes with time are called the behavior of a system.

### The state diagram

In the embedded world, the state diagram is one of the means used to capture, describe and specify the behavior of a system. In a state diagram, each state is represented by a circle, node, or vertex. We label each node to identify the state. A memory device has two states-its output is a logical 0 or 1, thus to express its behavior we will need two nodes as shown in figure 2.12.

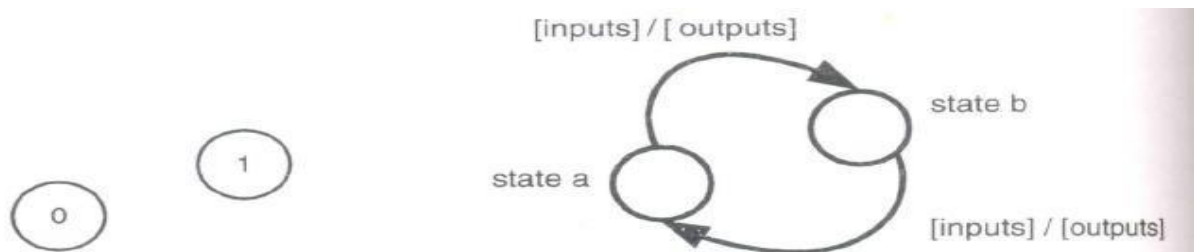

Figure 2.12 transition between states in a digital memory device

We show the transition between two states using a labeled directed line or arrow called arc as illustrated in figure because the line has a direction, the state diagram is referred to as a directed graph. The head or point of the arrow identifies the final state, and the tail or back of the arrow identifies the initial state.

## **Finite-state machine (FSM)- A theoretical model**

A finite-state machine (FSM) or finite-state automaton (plural: automata), or simply a state machine, is a mathematical model of computation used to design both computer programs and sequential logic circuits. It is conceived as an abstract machine that can be in one of a finite number of states. The machine is in only one state at a time; the state it is in at any given time is called the current state. It can change from one state to another when initiated by a triggering event or condition; this is called a transition. A particular FSM is defined by a list of its states, and the triggering condition for each transition.

The behavior of state machines can be observed in many devices in modern society which perform a predetermined sequence of actions depending on a sequence of events with which they are presented. Simple examples are vending machines which dispense products when the proper combination of coins are deposited, elevators which drop riders off at upper floors before going down, traffic lights which change sequence when cars are waiting, and combination locks which require the input of combination numbers in the proper order.

Finite-state machines can model a large number of problems, among which are electronic design automation, communication protocol design, language parsing and other engineering applications. In biology and artificial intelligence research, state machines or hierarchies of state machines have been used to describe neurological systems and in linguistics—to describe the grammars of natural languages.

Figure shows a simple finite-state machine having no inputs other than a clock and have only primitive outputs. such machines are referred to as autonomous clocks. A high level block diagram for a finite-state machine begins with the diagram in figure 2.13.

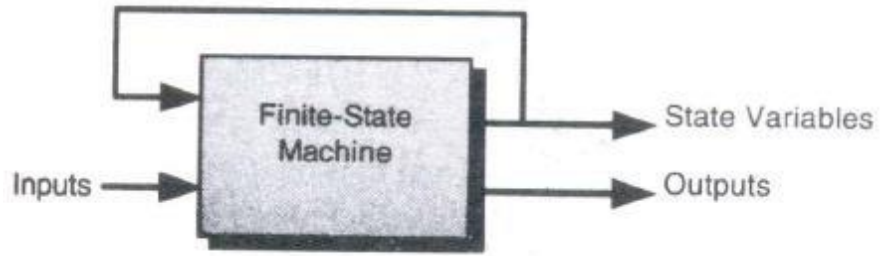

Figure 2.13 A high level block diagram for a finite-state machine

The output shown in the diagram may be the values of the state variables, combinations of the state variables ,or combinations of the state variables and the inputs.

## UNIT 3

### Memory

In a system, there are various types of memories. Figure 1.4 shows a chart for the various forms of memories that are present in systems. These are as follows:

- (i) Internal RAM of 256 or 512 bytes in a microcontroller for registers, temporary data and stack.
- (ii) (ii) Internal ROM/PROM/EPROM for about 4 kB to 16 kB of program (in the case of microcontrollers).
- (iii) (iii) External RAM for the temporary data and stack (in most systems).
- (iv) (iv) Internal caches (in the case of certain microprocessors).
- (v) (v) EEPROM or flash (in many systems saving the results of processing in nonvolatile memory: for example, system status periodically and digital-camera images, songs, or speeches after a suitable format compression).
- (vi) (vi) External ROM or PROM for embedding software (in almost all nonmicrocontroller-based systems).
- (vii) (vii) RAM Memory buffers at the ports. (viii) Caches (in superscalar microprocessors).

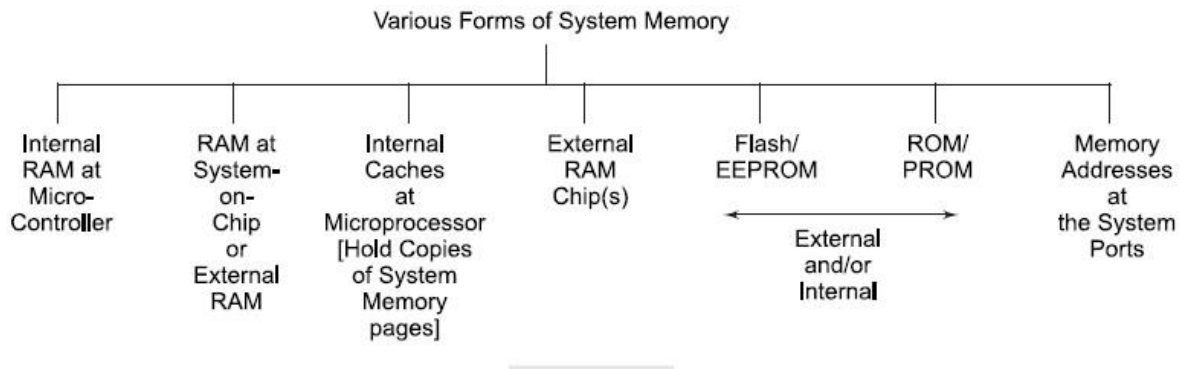

Table 1.1 gives the functions assigned in the embedded systems to the memories. ROM or PROM or EPROM embeds the embedded software specific to the system.

Table 1.1

<i>Functions Assigned to the Memories in a System</i>	
Memory Needed	Functions
ROM or EPROM	Storing Application programs from where the processor fetches the instruction codes. Storing codes for system booting, initializing, Initial input data and Strings. Codes for RTOS. Pointers (addresses) of various service routines.
RAM (Internal and External) and RAM for buffer	Storing the variables during program run and storing the stack. Storing input or output buffers, for example, for speech or image.
EEPROM or Flash	Storing non-volatile results of processing.
Caches	Storing copies of instructions and data in advance from external memories and storing temporarily the results during fast processing.

The memory unit in an embedded system should have low access time and high density (a memory chip has greater density if it can store more bits in the same amount of space). Memory in an embedded system consists of ROM (only read operations permitted) and RAM (read and write operations are permitted). The contents of ROM are non-volatile (power failure does not erase the contents) while RAM is volatile. The classification of the ROM is given in Figure 3.1. ROM stores the program code while RAM is used to store transient input or output data. Embedded systems generally do not possess secondary storage devices such as magnetic disks. As programs of embedded systems are small there is no need for virtual storage.

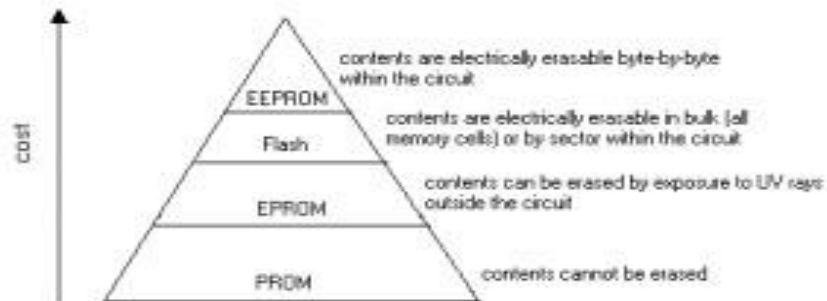

Figure 3.1: Classifications of ROM

### **Volatile memory**

A primary distinction in memory types is volatility. Volatile memories only hold their contents while power is applied to the memory device. As soon as power is removed, the memories lose their contents; consequently, volatile memories are unacceptable if data must be retained when the memory is switched off. Examples of volatile memories include static RAM (SRAM),

synchronous static RAM (SSRAM), synchronous dynamic RAM (SDRAM), and FPGA on-chip memory.

### Nonvolatile memory

Non-volatile memories retain their contents when power is switched off, making them good choices for storing information that must be retrieved after a system power-cycle. Processor boot-code, persistent application settings, and FPGA configuration data are typically stored in non-volatile memory. Although non-volatile memory has the advantage of retaining its data when power is removed, it is typically much slower to write to than volatile memory, and often has more complex writing and erasing procedures. Non-volatile memory is also usually only guaranteed to be erasable a given number of times, after which it may fail. Examples of non-volatile memories include all types of flash, EPROM, and EEPROM. Most modern embedded systems use some type of flash memory for non-volatile storage. Many embedded applications require both volatile and non-volatile memories because the two memory types serve unique and exclusive purposes. The following sections discuss the use of specific types of memory in embedded systems.

### ROM Overview

Although there are exceptions, the ROM is generally viewed as read only device. A high level interface to the ROM is as shown in figure 3.2. when the ROM is implemented, positions in the array that are to store a logical 0 have a transistor connected as shown in figure. Those positions intended to store a logical 1 have none.

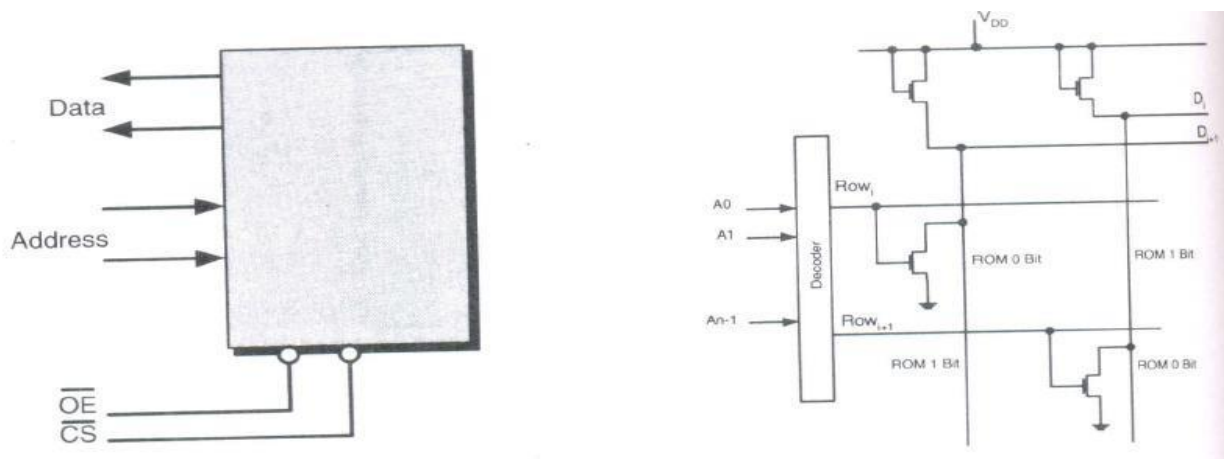

Figure 3.2 The ROM- outside and inside



### Read Operation

A value is read from a ROM by asserting one of the row lines. Those rows in which there is a transistor will be pulled to ground thereby expressing a logical 0. Those without the transistor will express a logical 1. Timing for a ROM read operation is given in figure 3.3.

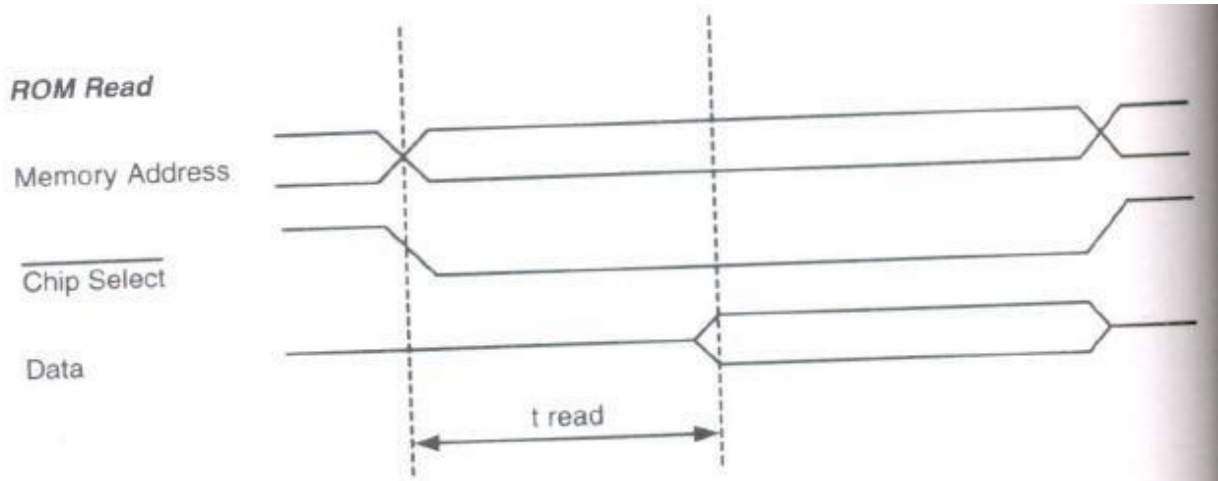

Figure 3.3 The ROM –read operation timing

### Static RAM overview

A high level interface to the SRAM is very similar to that for the ROM. The major differences arise from support for write capability. Figure 3.4 represents the major I/O signals and a typical cell in an SRAM array.

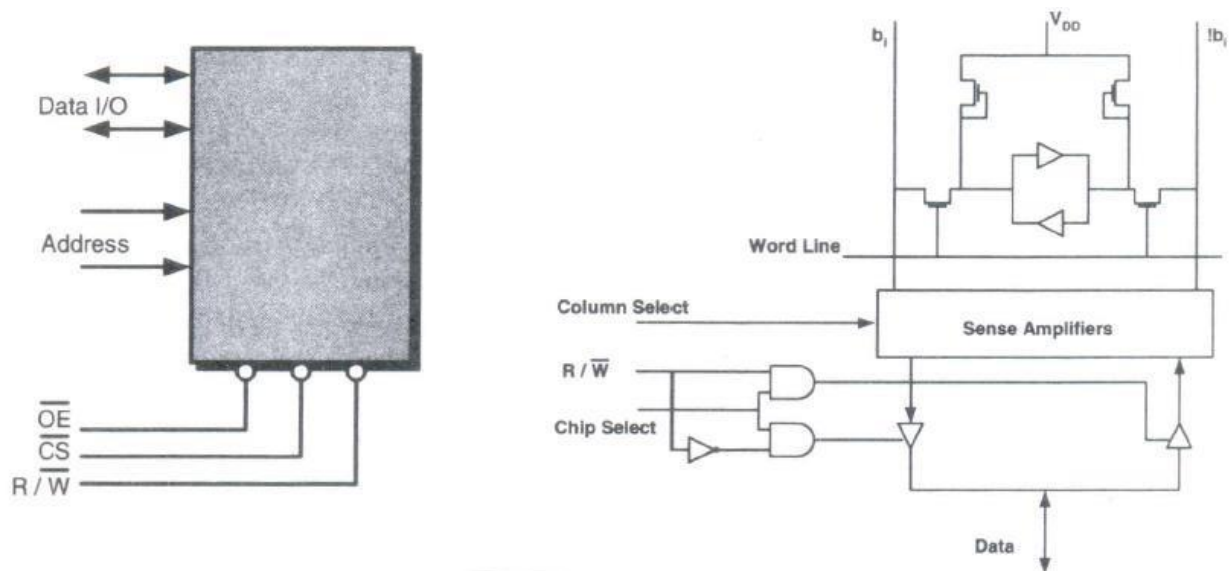

Figure 3.4 The SRAM – inside and outside

### Write operation

A value is written into the cell by applying a signal to  $b_i$  and  $b_{i\bar{}}$  through the write/sense amplifiers. Asserting the word line causes the new value to be written into the latch.

### Read Operation

A value is read from the cell by first precharging  $b_i$  and  $b_{i\bar{}}$  to a voltage that is halfway between a 0 and 1. The values are sensed and amplified by write/sense amplifier.

Typical timing for a read and write operation is shown in Figure 3.5 .

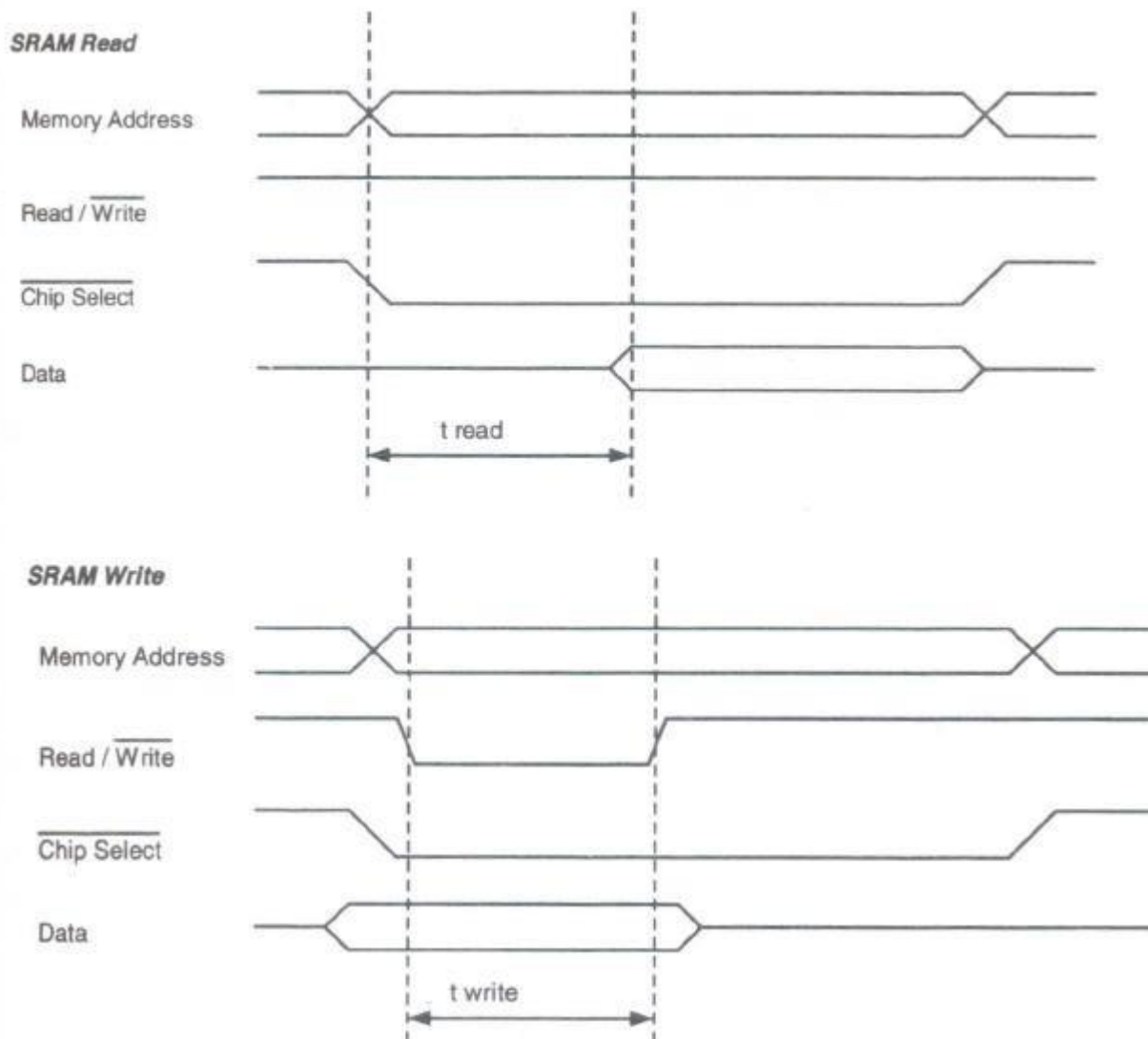

Figure 3.5 timing for the SRAM-read and write operation

## SDRAM

SDRAM is another type of volatile memory. It is similar to SRAM, except that it is dynamic and must be refreshed periodically to maintain its content. The dynamic memory cells in SDRAM are much smaller than the static memory cells used in SRAM. This difference in size translates into very high-capacity and low-cost memory devices. In addition to the refresh requirement, SDRAM has other very specific interface requirements which typically necessitate the use of special controller hardware. Unlike SRAM, which has a static set of address lines, SDRAM divides up its memory space into banks, rows, and columns. Switching between banks and rows incurs some overhead, so that efficient use of SDRAM involves the careful ordering of accesses. SDRAM also multiplexes the row and column addresses over the same address lines, which reduces the pin count necessary to implement a given size of SDRAM. Higher speed varieties of SDRAM such as DDR, DDR2, and DDR3 also have strict signal integrity requirements which need to be carefully considered during the design of the PCB. SDRAM devices are among the least expensive and largest-capacity types of RAM devices available, making them one of the most popular. Most modern embedded systems use SDRAM. A major part of an SDRAM interface is the SDRAM controller. The SDRAM controller manages all the address-multiplexing, refresh and row and bank switching tasks, allowing the rest of the system to access SDRAM without knowledge of its internal architecture.

### **Dynamic RAM Overview**

Larger microcomputer systems use Dynamic RAM (DRAM) rather than Static RAM (SRAM) because of its lower cost per bit. DRAMs require more complex interface circuitry because of their multiplexed address bus and because of the need to refresh each memory cell periodically.

A typical DRAM memory is laid out as a square array of memory cells with an equal number of rows and columns. Each memory cell stores one bit. The bits are addressed by using half of the bits (the most significant half) to select a row and the other half to select a column.

Each DRAM memory cell is very simple – it consists of a capacitor and a MOSFET switch. A DRAM memory cell is therefore much smaller than an SRAM cell which needs at least two gates to implement a flip-flop. A typical DRAM array appears as illustrated in figure 3.6 .

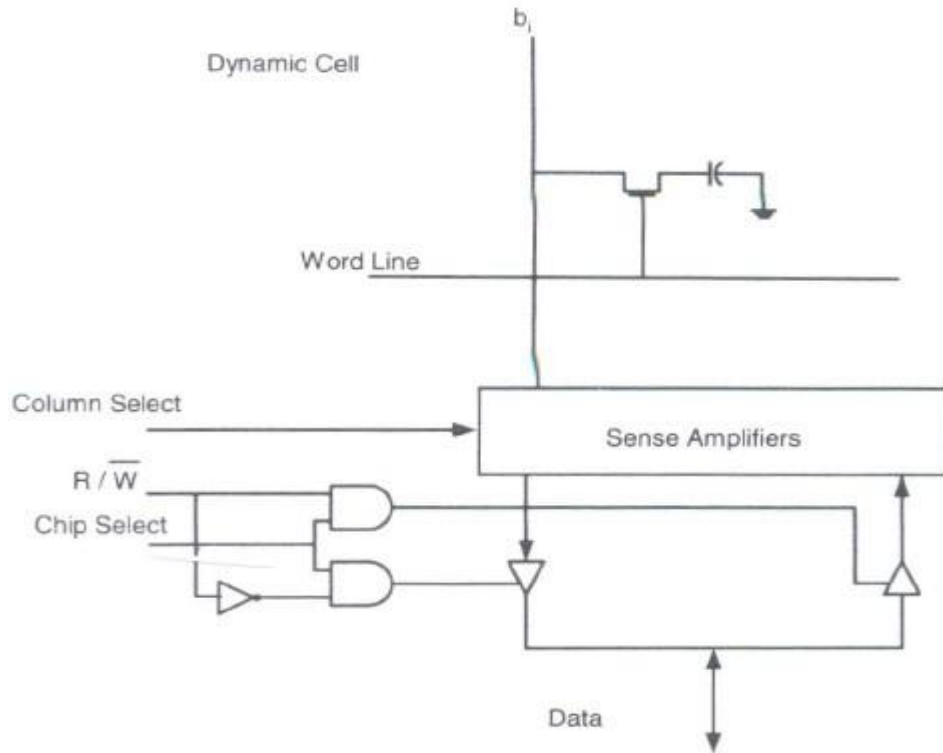

Figure 3.6 The DRAM inside

### Read Operation

A value is read from the cell by first precharging  $b_i$  and  $b_{i\text{bar}}$  to a voltage that is halfway between a 0 and 1. Asserting the word line enables the stored signal onto  $b_i$ . If the stored value is a logical 1, through charge sharing, the value on line  $b_i$  will increase. Conversely, if the stored value is a logical 0, charge sharing will cause the value on  $b_i$  to decrease. The change in the values are sensed and amplified by write/sense amplifier

### Write operation

A value is written into the cell by applying a signal to  $b_i$  and  $b_{i\text{bar}}$  through the write/sense amplifiers. Asserting the word line charges the capacitor if a logical 1 is to be stored and discharges if it a logical 0 to be stored.

Typical DRAM read and write timing is given in figure 3.7 .

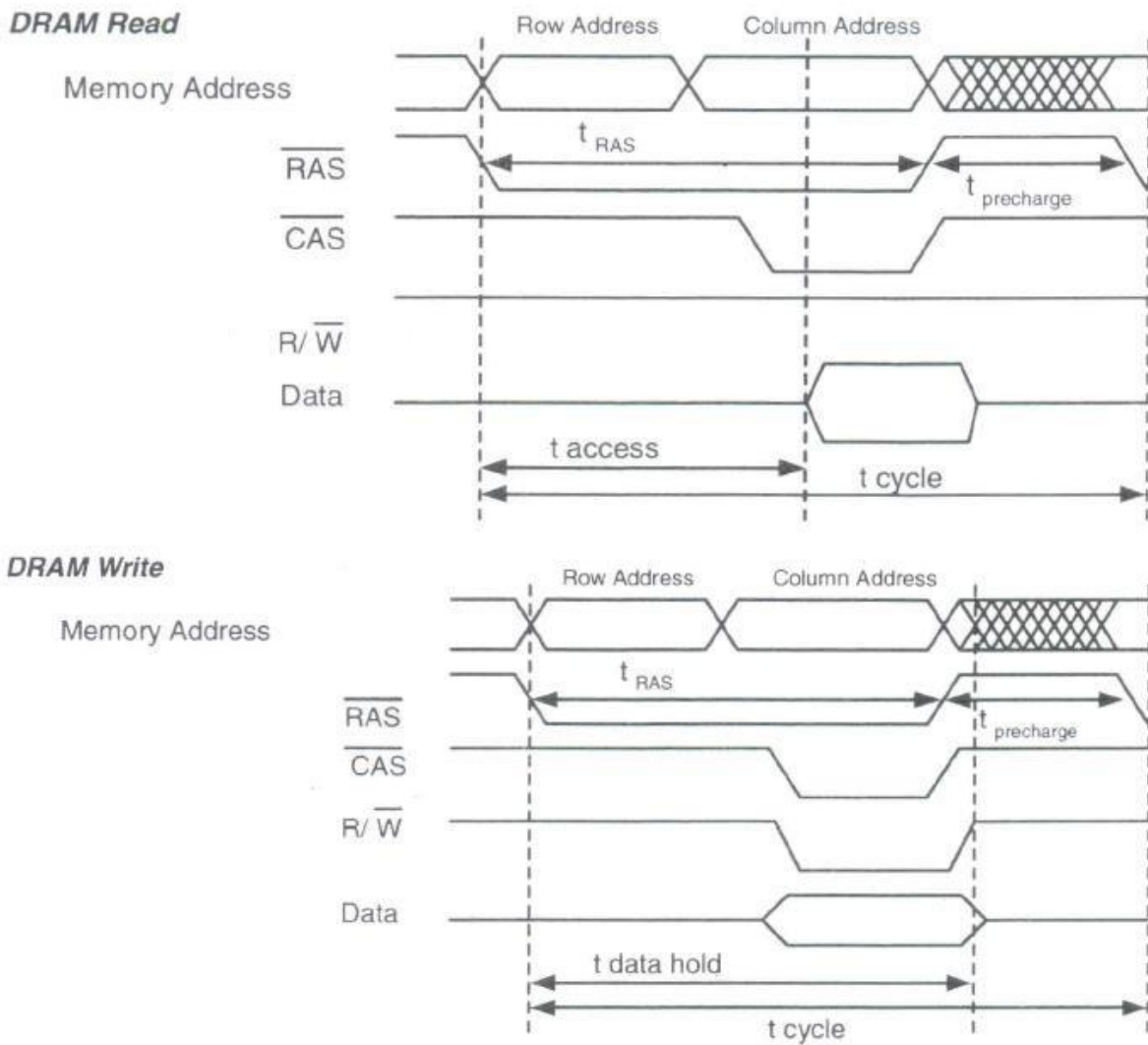

Figure 3.7 : Timing for the DRAM read and write cycles

### Chip organization

Independent type of internal storage, the typical memory chip appears as is shown in figure 3.8

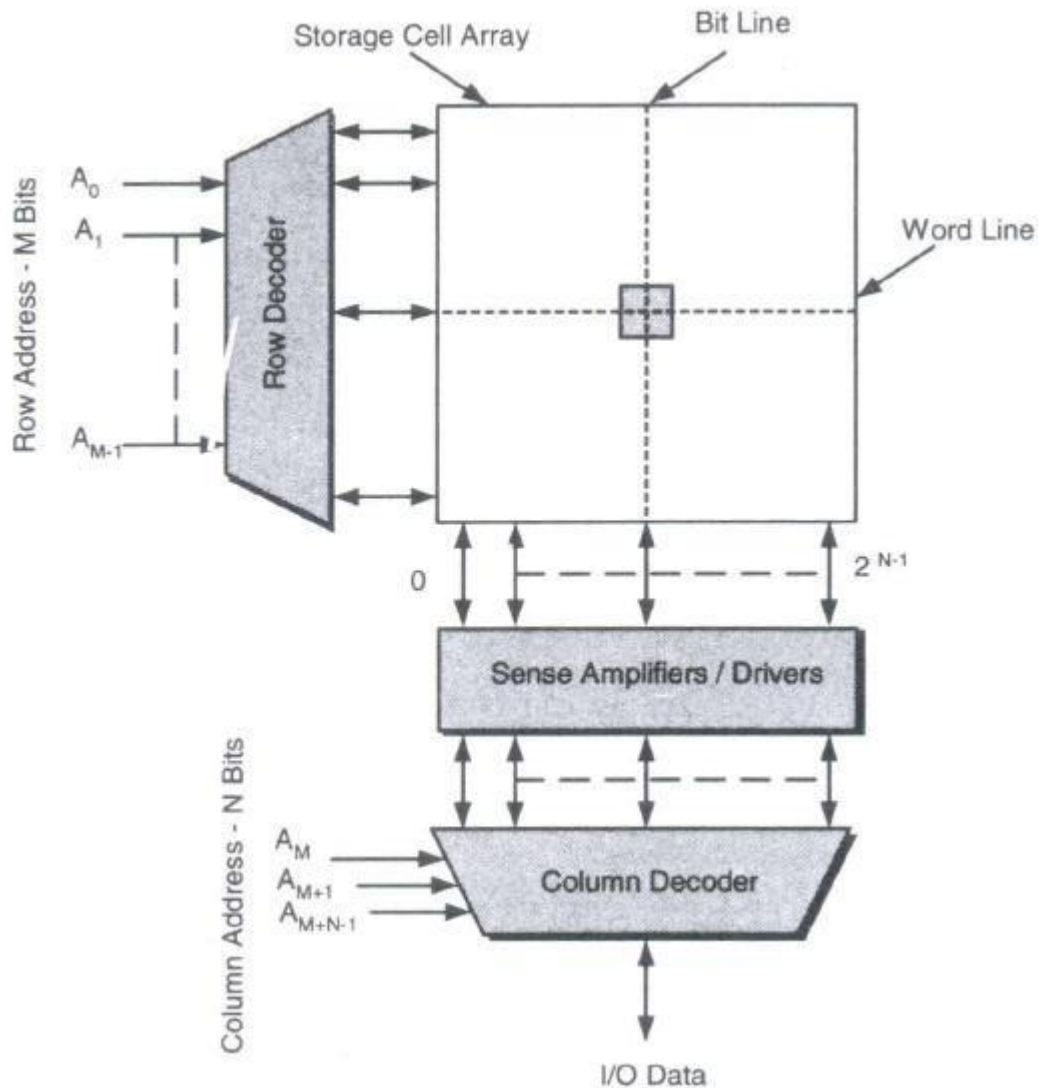

Figure 3.8 Typical memory chip internal architecture.

### A Memory interface in detail

If a single ROM or RAM chip is large enough and the address and the data I/O are wide enough to satisfy system memory requirements, then the interface is rather straightforward. We will look at the SRAM system and then the DRAM design.

### An SRAM design

A system specification requires an SRAM system that can store up to 4K 16 bit words..but the largest memory device available is 1K by 8. Thus it can store up to 1024 8 bit words. Consequently ,the design will require 8 of the smaller memory devices:2 sets of 4.

In worst case, to support 4K 16 bit words, 12 address lines and 16 data lines are required. The architecture of such system is given in figure 3.9

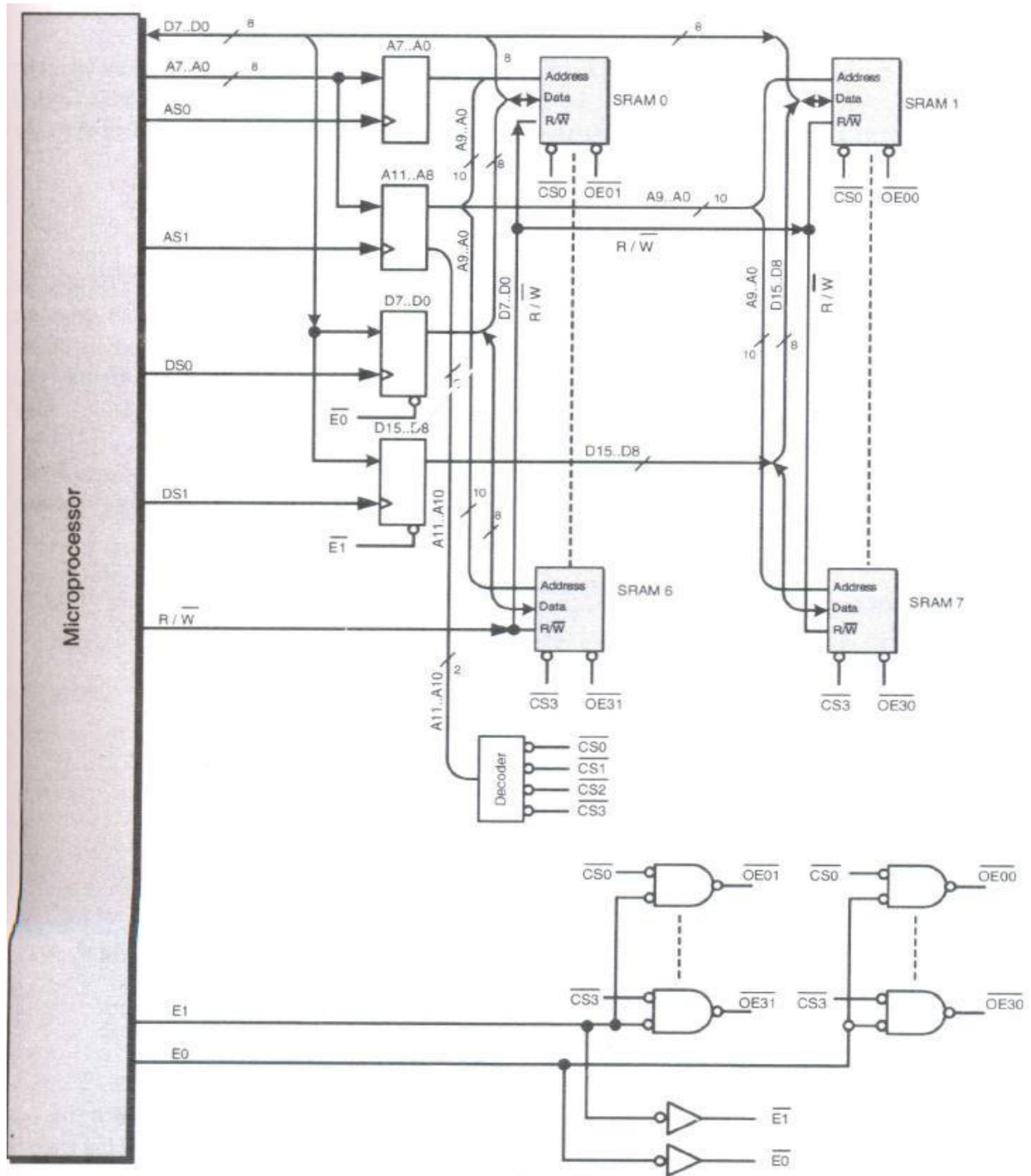

Figure 3.9: Design a 4K \*16 SRAM system

## A DRAM Design

The DRAM system will utilize an architecture that duplicates most of the previous SRAM systems. One major difference is the potential need to manage the refresh function. A second difference results from a memory size versus IC package size difficulty.

The relative timing for some of the signals in the base case is illustrated in figure 3.10.

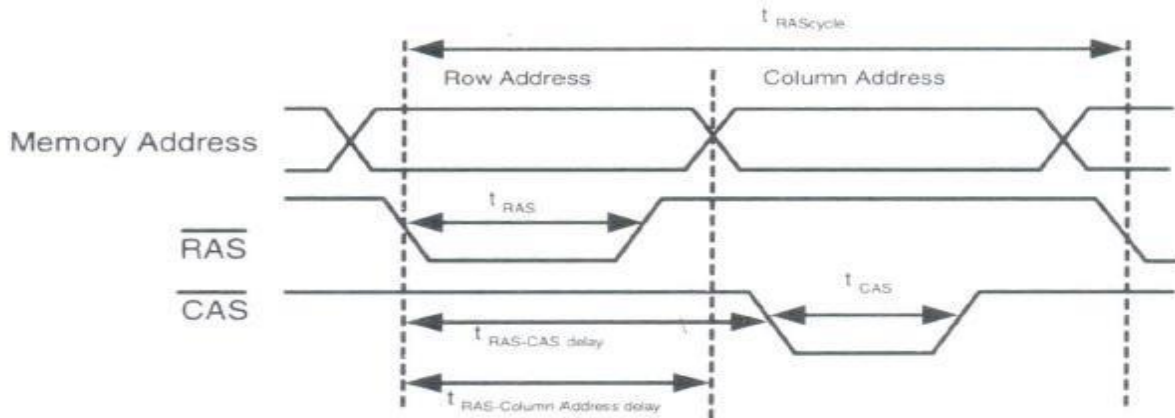

Figure 3.10 Basic DRAM timing

## The memory map

As a first step towards understanding the memory subsystem in an embedded application, we begin with a memory map. The map specifies the allocation and use of each location in the physical memory address space. A typical memory map for a small 16 bit machine is presented in figure 3.11

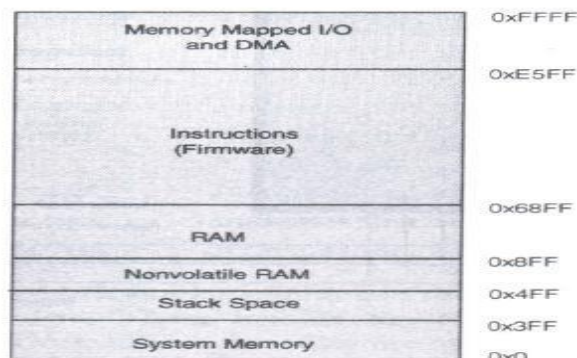

Figure 3.11 : Basic Memory map



This is the primary physical memory. From a high level perspective, the memory subsystem is comprised of two basic types:ROM and RAM. It is possible for the required code and data space to exceed total available primary memory.under such circumstances, one must use techniques called virtual memory and overlays to accommodate the expanded needs.

### Memory subsystem Architecture

The block labeled memory in the diagram for a vonneumann machine is actually comprised of a memory components of different size, kinds, and speeds arranged in a heirarchial manner and designed to cooperate with each other.such a hierarchy is given in figure 3.12 .

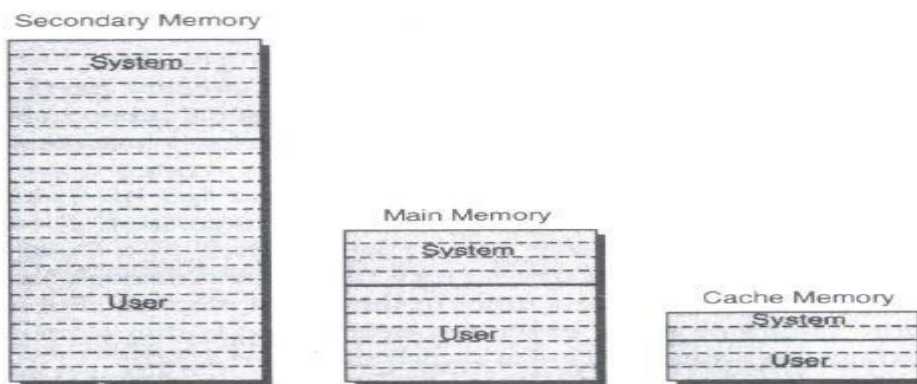

Figure 3.12 : Typical memory hierarchy utilizing a variety of memory types.

At the top are the slowest,largest and least expensive memories. These are known as secondary memory. At the bottom are the smallest,fastest,called cache memory. These are typically higher speed SRAM. These devices are more expensive.

### Basic concepts of Caching

A CPU cache is a cache used by the central processing unit of a computer to reduce the average time to access memory. The cache is a smaller, faster memory which stores copies of the data from frequently used main memory locations. As long as most memory accesses are cached memory locations, the average latency of memory accesses will be closer to the cache latency than to the latency of main memory.

Data is transferred between memory and cache in blocks of fixed size, called cache lines. When a cache line is copied from memory into the cache, a cache entry is created. The cache entry will include the copied data as well as the requested memory location (now called a tag).

When the processor needs to read or write a location in main memory, it first checks for a corresponding entry in the cache. The cache checks for the contents of the requested memory location in any cache lines that might contain that address. If the processor finds that the memory location is in the cache, a cache hit has occurred. However, if the processor does not find the memory location in the cache, a cache miss has occurred. In the case of:

- a cache hit, the processor immediately reads or writes the data in the cache line.
- a cache miss, the cache allocates a new entry, and copies in data from main memory. Then, the request is fulfilled from the contents of the cache.

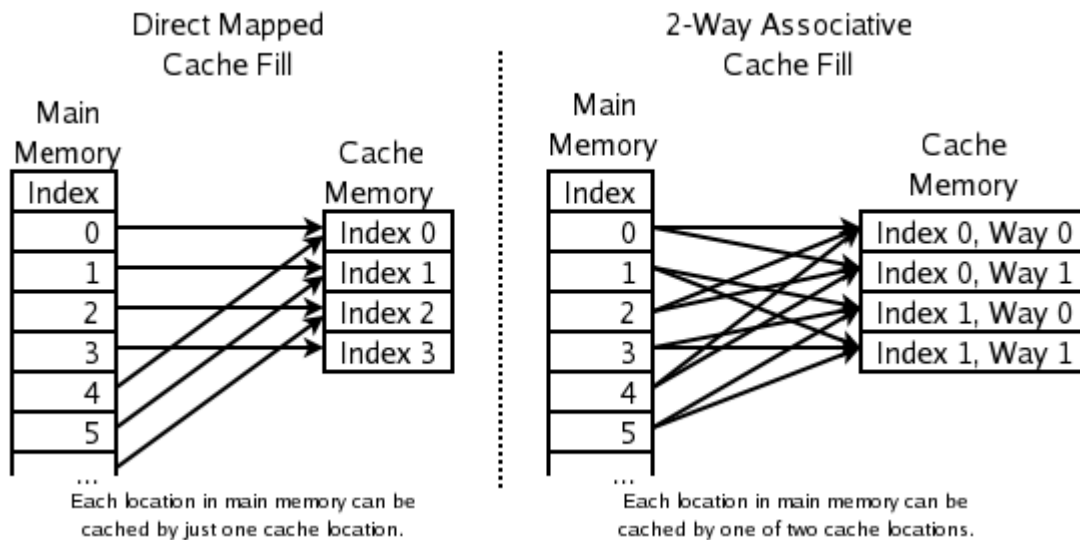

The replacement policy decides where in the cache a copy of a particular entry of main memory will go. If the replacement policy is free to choose any entry in the cache to hold the copy, the cache is called fully associative. At the other extreme, if each entry in main memory can go in just one place in the cache, the cache is direct mapped. Many caches implement a compromise in which each entry in main memory can go to any one of N places in the cache, and are described as N-way set associative. For example, the level-1 data cache in an AMD Athlon is 2-way set

associative, which means that any particular location in main memory can be cached in either of 2 locations in the level-1 data cache.

Associativity is a trade-off. If there are ten places to which the replacement policy could have mapped a memory location, then to check if that location is in the cache, ten cache entries must be searched. Checking more places takes more power, chip area, and potentially time. On the other hand, caches with more associativity suffer fewer misses so that the CPU wastes less time reading from the slow main memory. The rule of thumb is that doubling the associativity, from direct mapped to 2-way, or from 2-way to 4-way, has about the same effect on hit rate as doubling the cache size. Associativity increases beyond 4-way have much less effect on the hit rate and are generally done for other reasons

In order of worse but simple to better but complex:

- direct mapped cache — The best (fastest) hit times, and so the best tradeoff for "large" caches
- 2-way set associative cache
- 2-way skewed associative cache – In 1993, this was the best tradeoff for caches whose sizes were in the range 4K-8K bytes.
- 4-way set associative cache
- fully associative cache – the best (lowest) miss rates, and so the best tradeoff when the miss penalty is very high

Direct-mapped cache

Here each location in main memory can only go in one entry in the cache. It doesn't have a replacement policy as such, since there is no choice of which cache entry's contents to evict. This means that if two locations map to the same entry, they may continually knock each other out. Although simpler, a direct-mapped cache needs to be much larger than an associative one to give comparable performance, and is more unpredictable. Let 'x' be block number in cache, 'y' be block number of memory, and 'n' be number of blocks in cache, then mapping is done with the help of the equation  $x=y \bmod n$ .

2-way set associative cache

If each location in main memory can be cached in either of two locations in the cache, one logical question is: which one of the two? The simplest and most commonly used scheme, shown in the right-hand diagram above, is to use the least significant bits of the memory location's index as the index for the cache memory, and to have two entries for each index. One benefit of this scheme is that the tags stored in the cache do not have to include that part of the main memory address which is implied by the cache memory's index. Since the cache tags have fewer bits, they take less area on the microprocessor chip and can be read and compared faster. Also LRU is especially simple since only one bit needs to be stored for each pair.

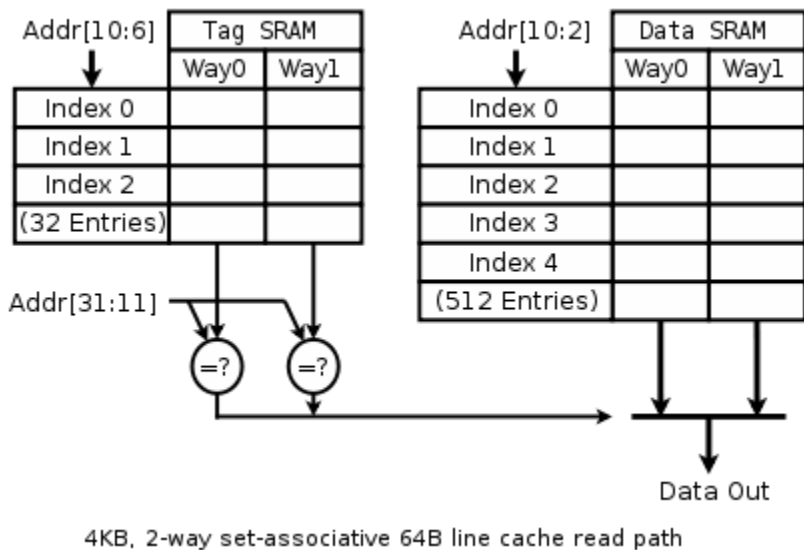

Cache reads are the most common CPU operation that takes more than a single cycle. Program execution time tends to be very sensitive to the latency of a level-1 data cache hit. A great deal of design effort, and often power and silicon area are expended making the caches as fast as possible.

The simplest cache is a virtually indexed direct-mapped cache. The virtual address is calculated with an adder, the relevant portion of the address extracted and used to index an SRAM, which returns the loaded data. The data is byte aligned in a byte shifter, and from there is bypassed to the next operation. There is no need for any tag checking in the inner loop — in fact, the tags need not even be read. Later in the pipeline, but before the load instruction is retired, the tag for the loaded data must be read, and checked against the virtual address to make sure there was a

cache hit. On a miss, the cache is updated with the requested cache line and the pipeline is restarted.

An associative cache is more complicated, because some form of tag must be read to determine which entry of the cache to select. An N-way set-associative level-1 cache usually reads all N possible tags and N data in parallel, and then chooses the data associated with the matching tag. Level-2 caches sometimes save power by reading the tags first, so that only one data element is read from the data SRAM.

The diagram to the right is intended to clarify the manner in which the various fields of the address are used. Address bit 31 is most significant, bit 0 is least significant. The diagram shows the SRAMs, indexing, and multiplexing for a 4 kB, 2-way set-associative, virtually indexed and virtually tagged cache with 64 B lines, a 32b read width and 32b virtual address.

Because the cache is 4 kB and has 64 B lines, there are just 64 lines in the cache, and we read two at a time from a Tag SRAM which has 32 rows, each with a pair of 21 bit tags. Although any function of virtual address bits 31 through 6 could be used to index the tag and data SRAMs, it is simplest to use the least significant bits.

Similarly, because the cache is 4 kB and has a 4 B read path, and reads two ways for each access, the Data SRAM is 512 rows by 8 bytes wide.

A more modern cache might be 16 kB, 4-way set-associative, virtually indexed, virtually hinted, and physically tagged, with 32 B lines, 32b read width and 36b physical addresses. The read path recurrence for such a cache looks very similar to the path above. Instead of tags, hints are read, and matched against a subset of the virtual address. Later on in the pipeline, the virtual address is translated into a physical address by the TLB, and the physical tag is read (just one, as the hint supplies which way of the cache to read). Finally the physical address is compared to the physical tag to determine if a hit has occurred.

## **Dynamic memory allocation**

Memory management is the act of managing computer memory. The essential requirement of memory management is to provide ways to dynamically allocate portions of memory to

programs at their request, and freeing it for reuse when no longer needed. This is critical to the computer system.

Several methods have been devised that increase the effectiveness of memory management. Virtual memory systems separate the memory addresses used by a process from actual physical addresses, allowing separation of processes and increasing the effectively available amount of RAM using paging or swapping to secondary storage. The quality of the virtual memory manager can have an extensive effect on overall system performance.

The task of fulfilling an allocation request consists of locating a block of unused memory of sufficient size. Memory requests are satisfied by allocating portions from a large pool of memory called the heap. At any given time, some parts of the heap are in use, while some are "free" (unused) and thus available for future allocations. Several issues complicate implementation, such as internal and external fragmentation, which arises when there are many small gaps between allocated memory blocks, which invalidates their use for an allocation request. The allocator's metadata can also inflate the size of (individually) small allocations. This is managed often by chunking. The memory management system must track outstanding allocations to ensure that they do not overlap and that no memory is ever "lost" as a memory leak.

We are more concerned with managing main memory to accommodate

- programs larger than main memory
- multiple processes in main memory.
- Multiple programs in main memory.

## **Overlays**

An overlay is a poor man's version of virtual memory. The overlay will be in ROM and used to accommodate a program that is larger than main memory. The program is segmented into a number of sections called overlays. The sections are

- Top level routine.
- Code to perform overlay process.
- Data segment for shared data.
- Overlay segment.

## **UNIT 5**

### **EMBEDDED SYSTEM DESIGN AND DEVELOPMENT**

#### **LIFE CYCLE MODELS**

The fundamentals of design are

- Find out what the customers want.
- Think of a way to give them what they want.
- Prove what you have done by building and testing it.
- Build a lot of the product to prove that it wasn't an accident.
- Use the product to solve the customer's problem.

The common life cycle models are:

- Waterfall model
- V cycle model.
- Spiral
- Rapid prototype

#### **Waterfall model**

The waterfall model represents a cycle- specifically a series of steps appearing much like a waterfall. It is the model which is use to linear process development. It is a sequential design process, often used in software process development in which progress is seen as flowing steadily downwards through the phases of Conception, Initiation, Analysis, Design, Construction, Testing, Production/Implementation and Maintenance. Figure 4.1 shows the water life cycle model

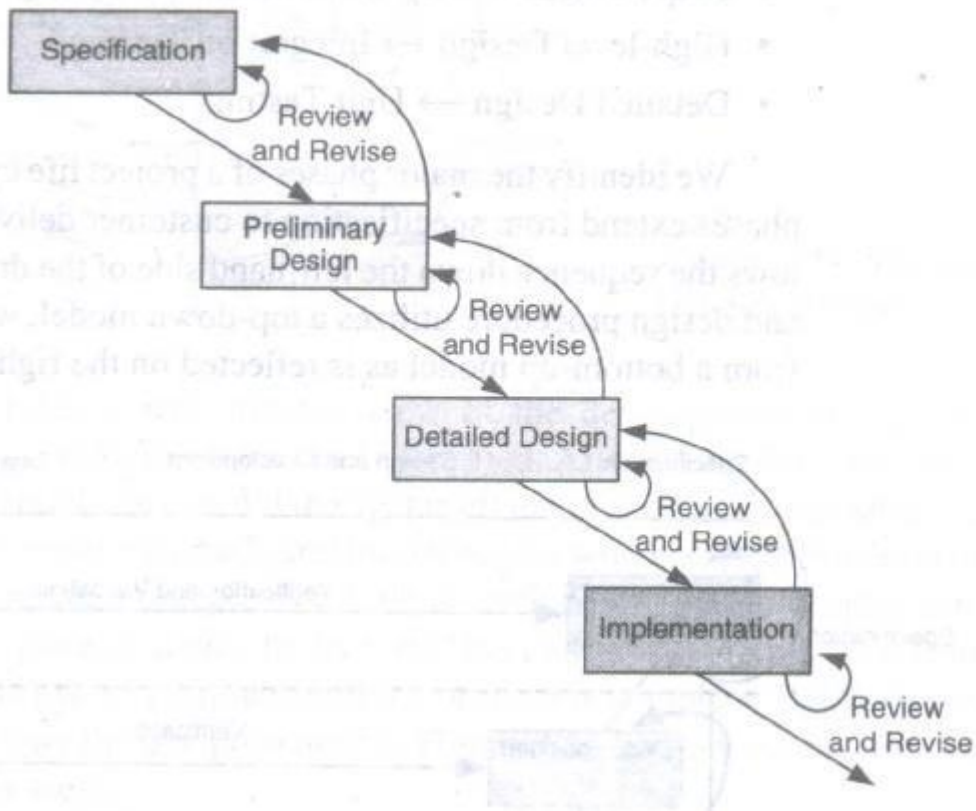

Figure 4.1 The waterfall life cycle model

The waterfall development model originates in the manufacturing and construction industries: highly structured physical environments in which after-the-fact changes are prohibitively costly, if not impossible. Since no formal software development methodologies existed at the time, this hardware-oriented model was simply adapted for software development.

The steps are:

- Specification.
- Preliminary design.
- Design review
- Detailed design.
- Design review.
- Implementation.
- Review.



Phases:

1) Requirement : In this phase we gather necessary information which will use for development of any project . For above example we gather information like which types of characteristics client wants. It also defines system requirement specification. This phase defines what to do.

2) Design: In design phase we then construct design to how to implement that requirements gathered into phase 1 .This phase define how to do .For this phase we then write algorithms

3) Coding: Now base on design phase we then write actual code to implement algorithms. This code should be efficient.

4)Testing : This phase use to test our coding part it checks all the validation...like our code should work for each and every possibilities of input if any bug occur then we have to report that bug to design phase or development phase.

5) Maintenance: In this phase we need keep updating information.

1. The implementation process contains software preparation and transition activities, such as the conception and creation of the maintenance plan; the preparation for handling problems identified during development; and the followup on product configuration management.

2. The problem and modification analysis process, which is executed once the application has become the responsibility of the maintenance group. The maintenance programmer must analyze each request, confirm it (by reproducing the situation) and check its validity, investigate it and propose a solution, document the request and the solution proposal, and, finally, obtain all the required authorizations to apply the modifications.

3. The process considering the implementation of the modification itself.

4. The process acceptance of the modification, by confirming the modified work with the individual who submitted the request in order to make sure the modification provided a solution.

5. The migration process is exceptional, and is not part of daily maintenance tasks. If the software must be ported to another platform without any change in functionality, this process will be used and a maintenance project team is likely to be assigned to this task.

6. Finally, the last maintenance process, also an event which does not occur on a daily basis, is the retirement of a piece of software.

### The V model

The V-Model is a term applied to a range of models, from a conceptual model designed to produce a simplified understanding of the complexity associated with systems development to detailed, rigorous development lifecycle models and project management models. Each test phase is identified with its matching development phase as shown in figure 4.2.

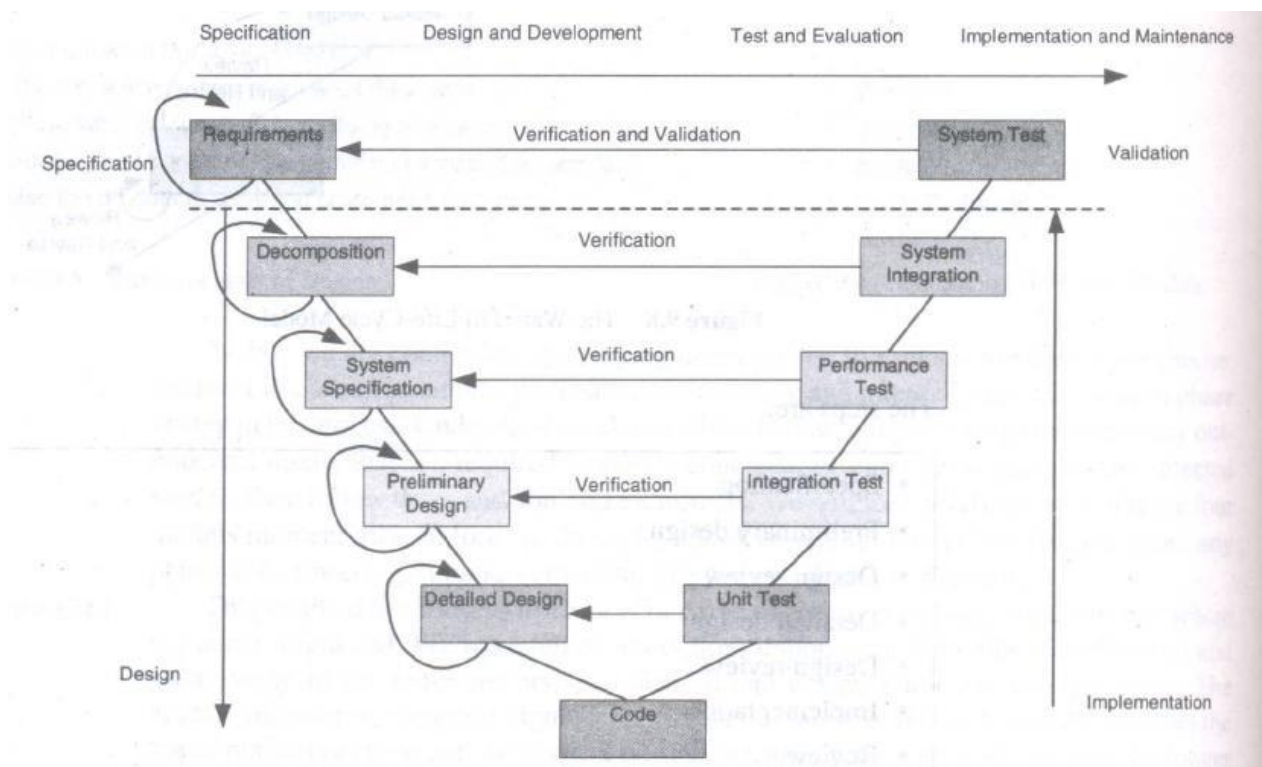

Figure 4.2 : The V life cycle model

In diagram, we have

- Requirement ↔ system/Functional Testing
- High level design ↔ Integration testing

- Detailed design ↔ Unit testing

The V-model is a graphical representation of the systems development lifecycle. It summarizes the main steps to be taken in conjunction with the corresponding deliverables within computerized system validation framework.

The V represents the sequence of steps in a project life cycle development. It describes the activities to be performed and the results that have to be produced during product development. The left side of the "V" represents the decomposition of requirements, and creation of system specifications. The right side of the V represents integration of parts and their validation

- Validation. The assurance that a product, service, or system meets the needs of the customer and other identified stakeholders. It often involves acceptance and suitability with external customers. Contrast with verification."
- "Verification. The evaluation of whether or not a product, service, or system complies with a regulation, requirement, specification, or imposed condition. It is often an internal process. Contrast with validation."

### **The spiral model**

The spiral model is a software development process combining elements of both design and prototyping-in-stages, in an effort to combine advantages of top-down and bottom-up concepts. Also known as the spiral lifecycle model (or spiral development), it is a systems development method (SDM) used in information technology (IT). This model of development combines the features of the prototyping and the waterfall model. The spiral model is intended for large, expensive and complicated projects. A simplified version of that model is presented in figure 4.3.

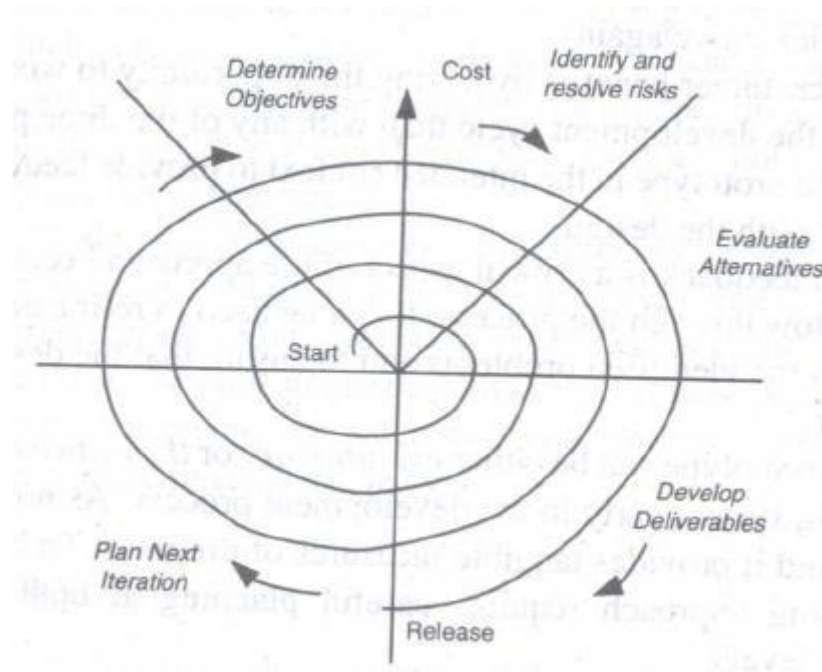

Figure 4.3 The spiral life cycle model steps

The steps in spiral model life cycle are

- Determine objective, alternatives, and constraints.
- Identify and resolve risks.
- Evaluate alternatives.
- Develop deliverables-verify that they are correct.
- Plan the next iteration.
- Commit to an approach for the next iteration.

The spiral model combines the idea of iterative development (prototyping) with the systematic, controlled aspects of the waterfall model. It allows for incremental releases of the product, or incremental refinement through each time around the spiral. The spiral model also explicitly includes risk management within software development. Identifying major risks, both technical and managerial, and determining how to lessen the risk helps keep the software development process under control.

The spiral model is based on continuous refinement of key products for requirements definition and analysis, system and software design, and implementation (the code). At each iteration

around the cycle, the products are extensions of an earlier product. This model uses many of the same phases as the waterfall model, in essentially the same order, separated by planning, risk assessment, and the building of prototypes and simulations

Documents are produced when they are required, and the content reflects the information necessary at that point in the process. All documents will not be created at the beginning of the process, nor all at the end (hopefully). Like the product they define, the documents are works in progress. The idea is to have a continuous stream of products produced and available for user review.

The spiral lifecycle model allows for elements of the product to be added in when they become available or known. This assures that there is no conflict with previous requirements and design. This method is consistent with approaches that have multiple software builds and releases and allows for making an orderly transition to a maintenance activity. Another positive aspect is that the spiral model forces early user involvement in the system development effort. For projects with heavy user interfacing, such as user application programs or instrument interface applications, such involvement is helpful

Note that the requirements activity takes place in multiple sections and in multiple iterations, just as planning and risk analysis occur in multiple places. Final design, implementation, integration, and test occur in iteration 4. The spiral can be repeated multiple times for multiple builds. Using this method of development, some functionality can be delivered to the user faster than the waterfall method. The spiral method also helps manage risk and uncertainty by allowing multiple decision points and by explicitly admitting that all of anything cannot be known before the subsequent activity starts.

### **Rapid prototype**

The Rapid prototyping model is intended to provide a rapid implementation of high level portions of both the software and the hardware . the approach allows developers to construct working portion of hardware and software in incremental stages.Each stage through the cycle,one incorporates a little more of the intended functionality.The prototype is useful for both the designer and the customer. The prototype can be either evolutionary or throughway. It has the advantage of having a working system early in development process.

## Problem solving-five steps to design

The 5 steps to a successful design are

- Requirement definition.
- System specification
- Functional design
- Architectural design
- Prototyping.

## The design process

The design process comprises five distinct stages although it may vary for particular projects or design disciplines. This information may be useful when working with a designer to understand the processes involved. Before the project is started however, a vital question has to be asked:

-Why do you need a new identity, brochure or website etc?|| This question is the key to undertaking a successful project.

## Identifying and formulating the requirement specification

Requirements analysis in systems engineering and software engineering, encompasses those tasks that go into determining the needs or conditions to meet for a new or altered product, taking account of the possibly conflicting requirements of the various stakeholders, analyzing, documenting, validating and managing software or system requirements. Figure 4.4 shows the interface between the customer and the design process.

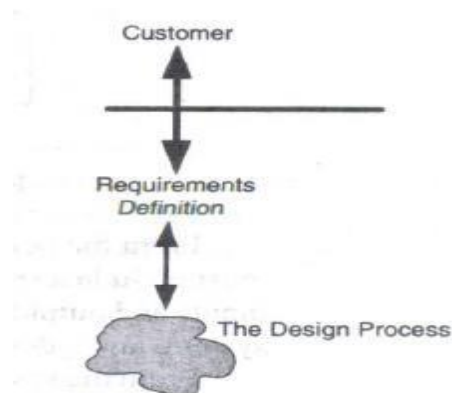

Figure 4.4 The interface between the customer and the design process.

Requirements analysis is critical to the success of a systems or software project. The requirements should be documented, actionable, measurable, testable, traceable, related to identified business needs or opportunities, and defined to a level of detail sufficient for system design.

Conceptually, requirements analysis includes three types of activities

- Eliciting requirements: the task of identifying the various types of requirements from various sources including project documentation, business process documentation, and stakeholder interviews. This is sometimes also called requirements gathering.
- Analyzing requirements: determining whether the stated requirements are clear, complete, consistent and unambiguous, and resolving any apparent conflicts.
- Recording requirements: Requirements may be documented in various forms, usually including a summary list and may include natural-language documents, use cases, user stories, or process specifications.

### **Characterizing the system**

Requirements analysis can be a long and arduous process during which many delicate psychological skills are involved. New systems change the environment and relationships between people, so it is important to identify all the stakeholders, take into account all their needs and ensure they understand the implications of the new systems. Analysts can employ several techniques to elicit the requirements from the customer. These may include the development of scenarios, the identification of use cases, the use of workplace observation or ethnography, holding interviews, or focus groups and creating requirements lists. Prototyping may be used to develop an example system that can be demonstrated to stakeholders. Where necessary, the analyst will employ a combination of these methods to establish the exact requirements of the stakeholders, so that a system that meets the business needs is produced.

The specification of the external environment should contain the following for each entity:

- Name and description of the entity.  
For each I/O variable, the following information is available

- The name of the signal.
- The use of the signal as an i/p or o/p.
- The nature of the signal as an event,data,state variable.
- Responsibilities-activities.
- Relationships.
- Safety and reliability.

### **The system design specification**

The System Design Specification (SDS) is a complete document that contains all of the information needed to develop the system. Systems design is the process of defining the architecture, components, modules, interfaces, and data for a system to satisfy specified requirements. Systems design could be seen as the application of systems theory to product development. There is some overlap with the disciplines of systems analysis, systems architecture and systems engineering. System design specification serves as a bridges between the customers and designers as shown in figure 4.5.

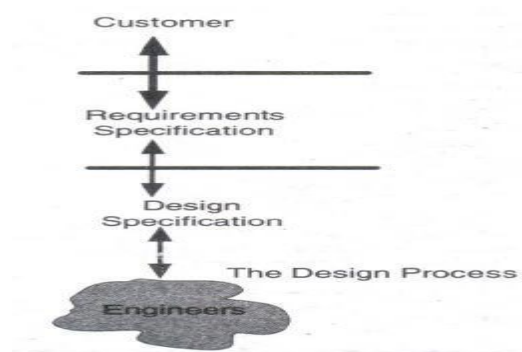

Figure 4.5: The Customer, the requirement, the design and the engineer

The requirement specifications provides a view from the outside of the system, design specification provides a view from the inside looking out as well. Design specification has 2 masters:

- It must specify the system's public interface from inside the system.
- It must specify how the requirements defined for and by the public interface are to be met by the initial functions of the system.



Five areas should be considered are:

- Geographical constraints.
- Characterization of and constraints on interface signals.
- User interface requirements
- Temporal constraints.
- Electrical infrastructure consideration
- Safety and reliability

### **System specification versus system requirements**

- Requirements give a description of something wanted or needed. They are a set of needed properties.
- Specification is a description of some entity that has or implements those properties.

A System Requirements Specification is a structured collection of information that embodies the requirements of a system.

Requirements and specifications are very important components in the development of any embedded system. Requirements analysis is the first step in the system design process, where a user's requirements should be clarified and documented to generate the corresponding specifications. While it is a common tendency for designers to be anxious about starting the design and implementation, discussing requirements with the customer is vital in the construction of safety-critical systems. For activities in this first stage has significant impact on the downstream results in the system life cycle.

For example, errors developed during the requirements and specifications stage may lead to errors in the design stage. When this error is discovered, the engineers must revisit the requirements and specifications to fix the problem. This leads not only to more time wasted but also the possibility of other requirements and specifications errors. Many accidents are traced to requirements flaws, incomplete implementation of specifications, or wrong assumptions about the requirements. While these problems may be acceptable in non-safety-critical systems, safety-critical systems cannot tolerate errors due to requirements and specifications. Therefore, it is

necessary that the requirements are specified correctly to generate clear and accurate specifications.

There is a distinct difference between requirements and specifications. A requirement is a condition needed by a user to solve a problem or achieve an objective. A specification is a document that specifies, in a complete, precise, verifiable manner, the requirements, design, behavior, or other characteristics of a system, and often, the procedures for determining whether these provisions have been satisfied. For example, a requirement for a car could be that the maximum speed to be at least 120mph. The specification for this requirement would include technical information about specific design aspects. Another term that is commonly seen in books and papers is requirements specification which is a document that specifies the requirements for a system or component. It includes functional requirements, performance requirements, interface requirements, design requirements, and development standards.

A specification is a precise description of the system that meets stated requirements. A specification document should be

- Complete
- Consistent
- Comprehensible
- Traceable to the requirement
- Unambiguous
- Modifiable
- Able to be written

### **Functional design**

The functional design process maps the "what to do" of the Requirements Specification into the "how to do it" of the design specifications. During this stage, the overall structure of the product is defined from a functional viewpoint. The functional design describes the logical system flow, data organization, system inputs and outputs, processing rules, and operational characteristics of the product from the user's point of view. The functional design is not concerned with the software or hardware that will support the operation of the product or the physical organization

of the data or the programs that will accept the input data, execute the processing rules, and produce the required output.

Functional Design is a paradigm used to simplify the design of hardware and software devices such as computer software and increasingly, 3D models. A functional design assures that each modular part of a device has only one responsibility and performs that responsibility with the minimum of side effects on other parts. Functionally designed modules tend to have low coupling.

### **Architectural design**

The major objective of the Architectural design activity is the allocation or mapping of the different pieces of system functionality to the appropriate hardware and software blocks. Work is based on the detailed functional structure. The important constraints that must be considered include items as

- The geographical distribution.
- Physical and user interfaces
- System performance specifications.
- Timing constraints and dependability requirements
- Power consumption
- Legacy components and cost.

### **Hardware and software specification and design**

For the software design, the following must be analyzed and decided.

- Whether to use a real time kernel.
- Whether several functions can be combined in order to reduce the number of software tasks and if so, how?
- A priority for each task.
- An implementation technique for each intertask relationship.

The important criteria that we strive to optimize are

- Implementation cost
- Development time and cost
- Performance and dependability constraints
- Power consumption
- Size

## **Functional model versus architectural model**

An appropriate model has to include elements both at the functional and architectural level to be able to represent and evaluate hardware/software system.

### **Functional model**

The functional model describes a system through a set of interacting functional elements. The design proceeds at a high level without initial bias toward any specific implementation. We have freedom to explore and to be creative. The functional models will interact using one of the following 3 types of relations

- The shared variable relation-which defines a data exchange without temporal dependencies.
- The synchronization relation- which specifies temporal dependency.
- The message transfer by port- which implies a producer/consumer kind of relationship.

### **Architectural model**

The architectural model describes the physical architecture of the system based on real components such as microprocessor, arrayed logics, special purpose processors, analog and digital components, and the many interconnections between them.

## **Prototyping**

The prototype phase leads to an operational system prototype. A prototype implementation includes

- Detailed design
- Debugging

- Validation
- Testing

A prototype is an early sample or model built to test a concept or process or to act as a thing to be replicated or learned from. It is a term used in a variety of contexts, including semantics, design, electronics, and software programming. A prototype is designed to test and trial a new design to enhance precision by system analysts and users. Prototyping serves to provide specifications for a real, working system rather than a theoretical one.

In many fields, there is great uncertainty as to whether a new design will actually do what is desired. New designs often have unexpected problems. A prototype is often used as part of the product design process to allow engineers and designers the ability to explore design alternatives, test theories and confirm performance prior to starting production of a new product. Engineers use their experience to tailor the prototype according to the specific unknowns still present in the intended design. For example, some prototypes are used to confirm and verify consumer interest in a proposed design whereas other prototypes will attempt to verify the performance or suitability of a specific design approach.

In general, an iterative series of prototypes will be designed, constructed and tested as the final design emerges and is prepared for production. With rare exceptions, multiple iterations of prototypes are used to progressively refine the design. A common strategy is to design, test, evaluate and then modify the design based on analysis of the prototype.

In many product development organizations, prototyping specialists are employed - individuals with specialized skills and training in general fabrication techniques that can help bridge between theoretical designs and the fabrication of prototypes.

## **Other Considerations**

The 2 additional complementary and concurrent activities that need to be considered are

- Capitalization and reuse
- Requirement and traceability management.

### **Capitalization and reuse**

## Capitalization

Capitalization and reuse are activities that are essential to the contemporary design process. Proper and efficient exploitation of intellectual properties is very important .intellectual properties are designs, often patented,that can be sold to another party to develop and sell as their product.

## Reuse

One of the main purpose of reuse is to help designers shorten the development life cycle. Component reuse is facilitated in 2 ways: present and future.

To be reused,a component needs to be

- Well defined
- Properly modularized
- In conformance to some interchange standard.

## **Requirement and traceability management**

### **Requirement traceability**

Requirement traceability refers to the ability to follow the life of a requirement in both the forward and reverse directions through the entire design process and the design. The few important pieces of informations are

- The means for the project manager and the customer to monitor the development progress.
- A path that can be used during the verification and validation of the product against the original specification.
- A means of identifying which hardware or software modules are affected if a requirement changes.

### **Requirement management**

Requirement management addresses

- Requirement specifications
- Changes
- Improvements
- Corrections

During the design, such changes are difficult to avoid for many reasons. Therefore a clear procedure that facilitates a way to accommodate such modifications has to be used during the whole design process.

## **Archiving the project**

When the product has finally been released to production, some work remains to be done. If the product follows the typical life cycle, bugs that must be fixed will be expected and added, and the next generation product will build on the current. The typical project will have had many contributors. A basic list can include

- Product planning
- Design and development
- Test
- Manufacturing
- Marketing
- Sales

Each group will have information, knowledge, documentation, and tools that will be important in future. figure depicts a typical project software directory.

# Performance Analysis and Optimization

## Performance or efficiency measures

Performance is a measure of the results achieved. Performance efficiency is the ratio between effort expended and results achieved. The difference between current performance and the theoretical performance limit is the performance improvement zone.

Another way to think of performance improvement is to see it as improvement in four potential areas. First, is the resource INPUT requirements (e.g., reduced working capital, material, replacement/reorder time, and set-up requirements). Second, is the THROUGHPUT requirements, often viewed as process efficiency; this is measured in terms of time, waste, and resource utilization. Third, OUTPUT requirements, often viewed from a cost/price, quality, functionality perspective. Fourth, OUTCOME requirements, did it end up making a difference.

Performance improvement is the concept of measuring the output of a particular process or procedure, then modifying the process or procedure to increase the output, increase efficiency, or increase the effectiveness of the process or procedure. The concept of performance improvement can be applied to either individual performance such as an athlete or organizational performance such as a racing team or a commercial enterprise.

In Organizational development, performance improvement is the concept of organizational change in which the managers and governing body of an organization put into place and manage a program which measures the current level of performance of the organization and then generates ideas for modifying organizational behavior and infrastructure which are put into place to achieve higher output. The primary goals of organizational improvement are to increase organizational effectiveness and efficiency to improve the ability of the organization to deliver goods and or services. A third area sometimes targeted for improvement is organizational efficacy, which involves the process of setting organizational goals and objectives.



Performance improvement at the operational or individual employee level usually involves processes such as statistical quality control. At the organizational level, performance improvement usually involves softer forms of measurement such as customer satisfaction surveys which are used to obtain qualitative information about performance from the viewpoint of customers.

The difficulty is the significant variability one encounters when running the program.

- What input data?
- What hardware platform?
- What compiler?
- What compiler options>

We can focus on several major areas:

- Complexity
- Time
- Power consumption
- Memory size
- Cost
- Weight

Other considerations include

- Development time
- Ease of maintenance
- Extensibility

The following considerations are

- Best or minimum case

- When referring to time, the emphasis is on measuring the ability to complete a task. Such a measure is an essential quantity in many real time scheduling algorithms.
- With respect to cost, power or weight, the metric becomes a value below which one cannot remove any more parts.
- With respect to size, one is looking for the smallest amount needed.
- Average case
  - Gives a typical measure; often, this is sufficient.
- Worst case
  - The largest or longest value of a particular measure. When we refer to time, we are looking at an upper or lower bound on a schedule.

### **The system**

A system is a set of interacting or interdependent components forming an integrated whole<sup>[1]</sup> or a set of elements (often called 'components' ) and relationships which are different from relationships of the set or its elements to other elements or sets

We consider hardware to comprise

- Computational and control elements.
- Communication subsystem
- Memory

We consider software to be

- Algorithms and data structures.
- Control and scheduling.

### **Complexity analysis- A high level measure**

Complexity analysis involves breaking down a user task into a set of constituent steps and then calculating a complexity metric for each step in the task relative to the type of user. Complexity

analysis can also be used to provide relative comparisons of complexity between releases of a product.

The complexity of an algorithm is a function describing the efficiency of the algorithm in terms of the amount of data the algorithm must process. Usually there are natural units for the domain and range of this function. There are two main complexity measures of the efficiency of an algorithm:

- Time complexity is a function describing the amount of time an algorithm takes in terms of the amount of input to the algorithm. "Time" can mean the number of memory accesses performed, the number of comparisons between integers, the number of times some inner loop is executed, or some other natural unit related to the amount of real time the algorithm will take. We try to keep this idea of time separate from "wall clock" time, since many factors unrelated to the algorithm itself can affect the real time (like the language used, type of computing hardware, proficiency of the programmer, optimization in the compiler, etc.). It turns out that, if we chose the units wisely, all of the other stuff doesn't matter and we can get an independent measure of the efficiency of the algorithm.
- Space complexity is a function describing the amount of memory (space) an algorithm takes in terms of the amount of input to the algorithm. We often speak of "extra" memory needed, not counting the memory needed to store the input itself. Again, we use natural (but fixed-length) units to measure this. We can use bytes, but it's easier to use, say, number of integers used, number of fixed-sized structures, etc. In the end, the function we come up with will be independent of the actual number of bytes needed to represent the unit. Space complexity is sometimes ignored because the space used is minimal and/or obvious, but sometimes it becomes as important an issue as time.

## **The methodology**

The steps involved in analyzing a complexity of a problem perform trade-off analyses in the design cycle. They are

- Decompose the problem into a set of basic operations.
- Count the total number of such operations.

- Derive a formula, based in some parameter and that is the size of the problem.
- Use order of magnitudes estimation to assess behavior

## Analyzing code

As one gains facility in analyzing and understanding the behavior of a system, it becomes evident rather quickly that even the most complex parts of a system are ultimately composed of fundamental modules. Let's now analyze several of the basic flow of control construct that are commonly found in many algorithms. The analysis is done from the perspective of time performance.

### Constant Time statements

The execution of constant time statements ,is a constant, independent of the size of the input.

- Declarations and initializations of simple data types:  
Int x,y;  
Char mychar='a';
- Assignment statements of simple data types:  
x=y;
- Arithmetic operations:  
X=5.y+4.z;
- Array referencing:  
A[j]
- Referencing/ dereferencing pointers:  
Cursor=head-> next;
- Most conditional tests:  
If(x<12)....

## Looping construct

Looping constructs are a common flow of control mechanism. any loop analysis has 2 parts.

- Determine the number of iterations to be performed.
- Determine the number of steps per iteration.

## For loop

for loop is a programming language statement which allows code to be repeatedly executed. A for loop is classified as an iteration statement.

```
for (int i = 0; i < 100; i++) {  
    /* Prints the numbers 0 to 99, each separated by a space. */  
    System.out.print(i);  
    System.out.print(' ');  
}  
System.out.println();
```

### **While loop**

a while loop is a control flow statement that allows code to be executed repeatedly based on a given boolean condition. The while loop can be thought of as a repeating if statement.

```
int x = 0;  
while (x < 5)  
{  
    printf ("x = %d\n", x);  
    x++;  
}
```

### **Sequential statements**

For a sequence of statements, simply compute their individual complexity functions.

### **Conditional statements**

Conditional statements are features of a programming language which perform different computations or actions depending on whether a programmer-specified Boolean condition evaluates to true or false. Apart from the case of branch predication, this is always achieved by selectively altering the control flow based on some condition.

IF (Boolean condition) THEN

(Consequent)

ELSE

(Alternative)

END IF

When an interpreter finds an If, it expects a Boolean condition – for example,  $x > 0$ , which means "the variable x contains a number that is greater than zero" – and evaluates that condition. If the condition is true, the statements following the then are executed. Otherwise, the execution continues in the following branch – either in the else block (which is usually optional), or if there is no else branch, then after the end If.

After either branch has been executed, control returns to the point after the end If.

### **Analysis of Algorithms**

Efficiency of an algorithm can be measured in terms of:

- Execution time (time complexity)
- The amount of memory required (space complexity)

#### **Time complexity:**

For most of the algorithms associated with this course, time complexity comparisons are more interesting than space complexity comparisons. A measure of the amount of time required to execute an algorithm. Factors that should not affect time complexity analysis:

- The programming language chosen to implement the algorithm
- The quality of the compiler
- The speed of the computer on which the algorithm is to be executed

Time complexity analysis for an algorithm is independent of programming language, machine used. Objectives of time complexity analysis:

- To determine the feasibility of an algorithm by estimating an upper bound on the amount of work performed
- To compare different algorithms before deciding on which one to implement.

- Analysis is based on the amount of work done by the algorithm
- Time complexity expresses the relationship between the size of the input and the run time for the algorithm
- Usually expressed as a proportionality, rather than an exact function
- To simplify analysis, we sometimes ignore work that takes a constant amount of time, independent of the problem input size
- When comparing two algorithms that perform the same task, we often just

Concentrate on the differences between algorithms

Simplified analysis can be based on:

- Number of arithmetic operations performed
- Number of comparisons made
- Number of times through a critical loop
- Number of array elements accessed

### **Instructions in detail**

It is assumed that a program or algorithm is made up of several common flows of control constructs. The basic constructs will be analyzed, several additional caveats are in order.

- Single thread of execution is assumed.
- The analysis is conducted at the assembly language level. Each different compiler is going to generate somewhat different assembly code, even for the same target. The analysis must be based on the compiler that is generating the final code for the microprocessor used in the design.
- Compilers support different options for the compilation process. Such variations include the size of the target memory. Different code may be generated for a small memory model versus a large memory model.

Consistency is the keyword. always perform the analysis on the code that will ultimately be embedded in the system being designed.

A hardware interrupt is an electronic alerting signal sent to the processor from an external device, either a part of the computer itself such as a disk controller or an external peripheral. For example, pressing a key on the keyboard or moving the mouse triggers hardware interrupts that cause the processor to read the keystroke or mouse position.

### **Time ,etc- a more detailed look**

Time is one of the most critical constraints that must be considered when designing embedded system. we must consider both hardware and software timing. On the hardware side, one must consider the internal delays of the hardware components as well as the delays through external elements. Software performance is affected by both the path through the program and the timing of the individual instructions.

### **Metrics**

Response time- the interval between the occurrence of an event and the completion of some associated action.

Time loading- this is the percentage of time that the CPU is doing useful work.

Memory loading- this is the percentage of usable memory being used.

### **Response time**

Response time is the time a system or functional unit takes to react to a given input. In data processing, the response time perceived by the end user is the interval between

- (a) The instant at which an operator at a terminal enters a request for a response from a computer.
- (b) The instant at which the last character of the response is received at a terminal.



In a data system, the system response time is the interval between the receipt of the end of transmission of an inquiry message and the beginning of the transmission of a response message to the station originating the inquiry.

### **Polled loops**

Polled loops are the simplest and the response time consists of three components

- Hardware delays in the external device to set the signaling event.
- Time to test the flag
- Time needed to respond to and process the event associated with the flag.

### **Co-routine**

In a noninterrupt environment, the time for a co-routine may be computed directly or, more often, bounded, which we compute as the worst case path through each component.

### **Time loading**

Time loading is the percentage of time that the CPU is doing useful work. analyzing time loading entails the execution times of the constituent modules. These times are computed by finding the time spent in both the primary tasks and the support tasks. Then compute the ratio of

$$\frac{\textit{primary}}{\textit{primary} + \textit{secondary}}$$

To compute the times, three primary methods are used:

- Instruction counting
- Simulation
- Physical measurement

## Memory loading

Today, in many applications, memory is almost free. In many cases, however, it is not. The amount of memory available may be reduced to save weight in such applications as in aircraft or spacecraft. There may be severe cost constraints such as those found in very high-volume consumer products such as televisions or the automobile. There are also times when one must eliminate parts to reduce power, as is common in portable systems such as cell phones or the PDA. In such cases, one must optimize the use of what memory is available. As we learned earlier, memory has several different components: code space, data space, and system space. Recall once again that we optimize a design in order to focus most of the resources on getting the target application completed. Memory loading is defined as the percentage of usable memory being devoted to that application.

The memory map is a useful step for understanding the allocation and use of the available memory. For reference, a typical memory map is presented in Figure 14.29.

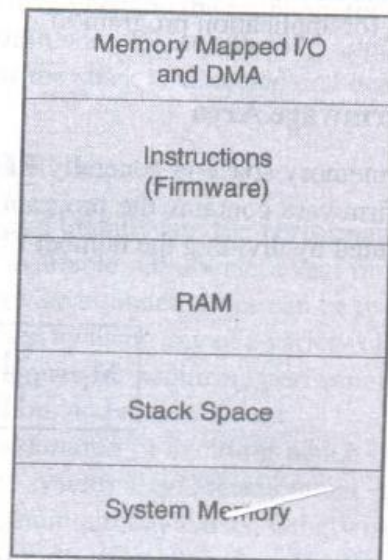

**Figure 14.29** A Typical Memory Map

The total memory loading will be the sum of the individual loadings for Instructions, Stack, and RAM. The loading is given by

$$M_T = M_i \cdot P_i + M_R \cdot P_R + M_S \cdot P_S \quad (14.2)$$

## Designing a Memory Map

When designing a memory map, allocate the minimum amount of memory necessary for the instructions and the stack, but be sure to allow room for future growth. Leave the remaining amount of RAM for application program(s).

### Instruction/Firmware Area

This portion of memory space is generally ROM of one form or another, hence its label firmware. The firmware contains the program that implements the application. Memory loading is computed by dividing the number of user locations by the maximum allowable. We get

$$M_I = \frac{U_I}{T_I} \quad (14.3)$$

### RAM Area

This portion of memory space is generally used for storing program data. Such data also includes any global variables and what are called RAM registers in some CPU architectures. Occasionally, RAM may be used for storing instructions. This is done to improve the instruction fetch speed or to support modifiable instructions. Generally, however, we prefer to avoid such things. Once again the instructions are called firmware because they are not intended to be changed.

The size of the RAM area is determined at design time. Thus, loading can only be determined after the design is completed. Memory loading is computed by dividing the number of user locations by the maximum allowable RAM area. Doing so gives

$$M_R = \frac{U_R}{T_R} \quad (14.4)$$

### Stack Area

The stack area is the portion of memory space used to store context information and auto variables. Depending on the design, one may have multiple stacks in this area of memory. From the point of view of the memory loading calculations, it is modeled as one single stack. The capacity is generally determined at design time, and the size is based on use at runtime. For the current calculations, one can establish a bound. Assume a maximum number of tasks and call that number  $t_{\max}$ . Next assume a maximum allocation for each task. Call the allocation  $s_{\max}$ . From these, the maximum stack size can be computed as

$$U_S = S_{\max} \cdot T_{\max} \quad (14.5)$$

Memory loading is computed by dividing  $U_S$  by the maximum allocated stack area to yield

$$M_R = \frac{U_R}{T_R} \quad (14.6)$$

With memory allocation, remember, Occam's razor applies—never allocate more space than necessary. Most operating systems allow for user control over the stack size. Specify a size, based on your analysis, that is large enough to get the job done without being too large. Be certain to understand the problem, for stack overflow can be dangerous. If you are developing multithreaded to multitasking applications without a purchased kernel, carefully manage how the stack is allocated and deallocated.

## **Thoughts on performance optimization**

When investigating how to improve the performance of a system, one should think of a few things. When optimizing, it is important to think about

1. What is being optimized?
2. Why is it being optimized?
3. What will be the effect on the overall program if the module being optimized is eliminated from the program?
4. Is the optimization appropriate to the operating context?

## **Performance optimization**

In order to improve the performance, we must look at the common mistakes that are often made when assessing and trying to improve performance

### **Common mistakes**

- Expecting improvement in one aspect of the design to improve the overall performance proportional to improvement.
- Using hardware independent metrics to predict performance.
- Using peak performance
- Comparing performance based on a couple of metrics
- Using synthetic benchmarks.

### **Tricks of the trade**

Response time and time loading can be reduced in a number of ways. Here are a couple of simple ones.

- Use lookup tables or combinational logic.
- Perform measurements and computations at a rate and significance that is consistent with the rate of change and values of the data, the type of arithmetic, and the number of significant digits calculated.

- Certain arithmetic calculations can be implemented through shifting operations rather than using a standard mathematical computation.
- Learn from the compiler experts. Compiler writers commonly use many tricks to reduce code size and to improve speed performance.
- Loop management.
- Flow of control optimization.
- Use registers and caches.
- Use only necessary values.
- Optimize a common path or frequently used code block. The most frequently used path or highly used code segment should be the most highly optimized.
- Use page mode accesses.
- Know when to use recursion vs iteration
- Macros and inlining functions.

### **Hardware accelerators**

One technique that can be used to gain significant performance increase with respect to a software implementation is to move some of the functionality to hardware. Such a collection of components is called a hardware accelerator. The accelerator is often attached to the CPU bus. Communication with the CPU is accomplished through many of the same techniques that have already been discussed.

- Shared variables.  
Implemented as data and control registers located in accelerator.
- Shared memory locations.  
We may use DMA

Hardware accelerators are used when there are functions whose operations do not map well onto the CPU. Possible examples include

- Bit and nit field operations.
- Differing precisions of arithmetic calculations.
- Very high speed arithmetic

- FFT calculations
- Multiples
- Very high speed or associative search.
- High demand input or output operations, with tight timing constraints and high throughput.
- Streaming applications including high speed audio and video. With such application, delays in the time domain translate directly to distortion in the frequency domain.

### **Caches and performance**

A CPU cache is a cache used by the central processing unit of a computer to reduce the average time to access memory. The cache is a smaller, faster memory which stores copies of the data from frequently used main memory locations. As long as most memory accesses are cached memory locations, the average latency of memory accesses will be closer to the cache latency than to the latency of main memory.

The proportion of accesses that result in a cache hit is known as the hit rate, and can be a measure of the effectiveness of the cache for a given program or algorithm.

Read misses delay execution because they require data to be transferred from memory much more slowly than the cache itself. Write misses may occur without such penalty, since the processor can continue execution while data is copied to main memory in the background.

Instruction caches are similar to data caches, but the CPU only performs read accesses (instruction fetches) to the instruction cache. (With Harvard architecture and modified Harvard architecture CPUs, instruction and data caches can be separated for higher performance, but they can also be combined to reduce the hardware overhead.)

In computer science, a cache is a component that transparently stores data so that future requests for that data can be served faster. The data that is stored within a cache might be values that have been computed earlier or duplicates of original values that are stored elsewhere. If requested data is contained in the cache (cache hit), this request can be served by simply reading the cache, which is comparatively faster. Otherwise (cache misses), the data has to be recomputed or fetched from its original storage location, which is comparatively slower. Hence,

the greater the number of requests that can be served from the cache, the faster the overall system performance becomes.

To be cost efficient and to enable an efficient use of data, caches are relatively small. Nevertheless, caches have proven themselves in many areas of computing because access patterns in typical computer applications have locality of reference. References exhibit temporal locality if data is requested again that has been recently requested already. References exhibit spatial locality if data is requested that is physically stored close to data that has been requested already.

Small memories on or close to the CPU can operate faster than the much larger main memory. Most CPUs since the 1980s have used one or more caches, and modern high-end embedded, desktop and server microprocessors may have as many as half a dozen, each specialized for a specific function. Examples of caches with a specific function are the D-cache and I-cache (data cache and instruction cache).